



***Marine Transmissions***

# **PRM 750**

## Workshop Manual



Issue: 2 1/2000

The following international symbols are used in this service manual.



**WARNING: THIS SYMBOL WARNS OF POSSIBLE PERSONAL INJURY**



**CAUTION: THIS SYMBOL WARNS OF POSSIBLE DAMAGE TO TRANSMISSION**

Newage Transmissions operate a policy of product improvement and therefore reserve the right to change specifications without prior notification. Whilst every effort is made to ensure complete accuracy of the information in this manual no liabilities for inaccuracies or the consequences thereof can be accepted by the manufacturer or the distributor/dealer who supplied the manual.

# CONTENTS

SECTION		PAGE
	List of illustrations	4
	Foreword	5
	Warranty information	5
	Pre-delivery test	5
	Identification plate information	6
<b>1</b>	<b>GENERAL DATA</b>	<b>7</b>
	1.1 Specifications	7
	1.2 Basic installation data	10
<b>2</b>	<b>INTRODUCTION</b>	<b>11</b>
<b>3</b>	<b>CONSTRUCTION</b>	<b>11</b>
	3.1 Gearcase	11
	3.2 Gear train	11
	3.3 Gear train - in-line	12
	3.3.1 Gear train - angle drive	12
	3.4 Oil pump	12
	3.5 Valve block	12
	3.6 Neutral safety start switch	13
<b>4</b>	<b>OPERATING SYSTEM</b>	<b>13</b>
	4.1 Output rotations	13
	4.2 Hydraulic system	14
	4.3 Lubrication	15
	4.4 Approved oils	15
<b>5</b>	<b>INSTALLATION</b>	<b>15</b>
	5.1 General	15
	5.2 Checking the engine flywheel housing	15
	5.3 Checking the engine flywheel	16
	5.4 Mounting the gearbox to the engine	16
	5.5 Oil cooler	17
	5.5.1 PRM750D standard gearbox	18
	5.5.2 PRM750D with power take-off	18
	5.5.3 PRM750A with angle drive	19
	5.5.4 PRM750C in-line	19
	5.5.5 PRM750A/PRM750C with power take off	20
	5.6 Alignment to propeller shaft	20
	5.7 Installation angle	21
	5.8 Twin installations	21
	5.9 Remote control operating unit	22
<b>6</b>	<b>OPERATION</b>	<b>23</b>
	6.1 First time usage	23
	6.2 Drive selection	23
	6.3 Trailing (freewheeling) the propeller	23
	6.4 Emergency operation	23
<b>7</b>	<b>ROUTINE MAINTENANCE</b>	<b>24</b>
	7.1 Initial maintenance (after 25 hours running)	24
	7.2 Daily checks	24
	7.3 Annual checks	24
	7.4 Winter storage	24
	7.5 Other maintenance operations	24

<b>SECTION</b>		<b>PAGE</b>
<b>8</b>	<b>FAULT FINDING</b>	<b>25</b>
<b>9</b>	<b>SERVICING AND REPAIRS - GENERAL</b>	<b>26</b>
<b>10</b>	<b>SERVICING AND REPAIRS - PROCEDURES</b>	<b>27</b>
	10.1 Valve block	28
	10.2 Oil pump assembly	28
	10.3 Oil strainer	28
	10.4 Removing transmission from the boat	28
	10.5 Removing the input and layshaft assemblies	29
	10.6 Servicing the input and layshaft assemblies	29
	10.6.1 Input shaft oil seal	29
	10.6.2 Drive end bearing	29
	10.6.3 Clutch assemblies	30
	10.6.4 Clutch gear	30
	10.6.5 Drive pinion	30
	10.6.6 Rear end bearing, piston rings and feeder	31
	10.7 Replacement of the input shaft and layshaft assemblies	31
	10.8 Servicing the output shaft assembly	32
	10.9 Re-fitting the output shaft assembly	32
	10.10 Shimming procedures	33
<b>11</b>	<b>POWER TAKE-OFF UNIT</b>	<b>34</b>
	11.1 To fit a PTO unit to an existing gearbox	34
	11.2 To repair an existing PTO unit	34
<b>12</b>	<b>8° DOWN ANGLE DRIVE UNIT</b>	<b>35</b>
	12.1 Retrofitting to an existing gearbox	35
	12.2 Replacement of angle drive gears and bearings	35
	12.3 Reassembling the angle drive	35
	12.4 Shimming the angle drive input shaft bearings	35
	12.5 Shimming the angle drive output shaft bearings	36
<b>13</b>	<b>IN-LINE GEARBOX</b>	<b>36</b>
	13.1 In-line unit removal	36
	13.2 Removal of in-line unit components	36
	13.3 Shimming the in-line unit	36
	13.4 In-line unit rebuild	36
<b>14</b>	<b>OPTIONAL TROLLING VALVE DESCRIPTION</b>	<b>37</b>
	14.1 Description	37
	14.2 Trolling valve installation data	37
	14.3 Trolling valve fitting instructions	39
<b>15</b>	<b>TOOL KIT</b>	<b>40</b>
	15.1 Tightening torques	40
<b>16</b>	<b>REPLACEMENT PARTS ORDERING</b>	<b>40</b>
	<b>REPLACEMENT PARTS LIST AND ASSEMBLY DRAWINGS</b>	<b>41</b>

**LIST OF ILLUSTRATIONS**

**PAGE**

Fig. 1	PRM750 - Sectional view	4
Fig. 2	Installation drawing	10
Fig. 3	Internal layout	11
Fig. 4	Oil pump mounting position	12
Fig. 5	Wiring diagram for neutral safety switch	13
Fig. 6	Hydraulic and lubricating oil circuits	14
Fig. 7	Checking trueness of flywheel and flywheel housing	16
Fig. 8	Engine and gearbox cooling circuit	17
Fig. 9	Oil cooler connections PRM750	18
Fig. 10	Oil cooler with PTO	18
Fig. 11	Oil cooler connections PRM750A angle drive	19
Fig. 12	Oil cooler connections PRM750C in-line	19
Fig. 13	Oil cooler connections PRM750A/C with PTO	20
Fig. 14	Propeller rotation, twin installations	21
Fig. 15	Operating lever movement for ahead drive, twin installations	22
Fig. 16	Fitting of piston rings	31
Fig. 17	Shimming procedure	33
Fig. 18	Shimming procedure	33
Fig. 19	Shimming procedure	33
Fig. 20	Fitting PTO unit to existing PRM750	34
Fig. 21	PTO components	34
Fig. 22	Trolling Valve installation data	37
Fig. 23	Trolling Valve installation data	37
Fig. 24	Trolling Valve installation data	38
Fig. 25	Trolling Valve electrical circuit	38
Fig. 26	Trolling Valve basic circuit diagram	38
Fig. 27	Trolling Valve schematic	38

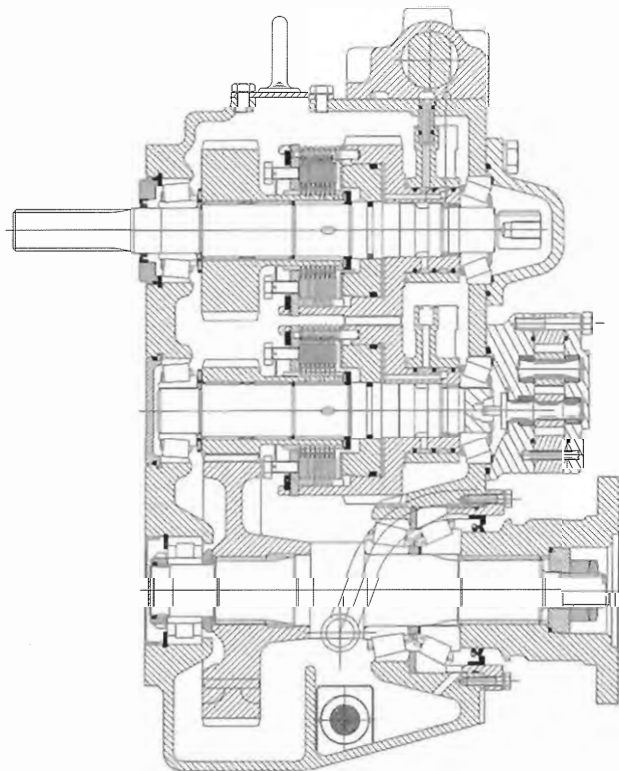

**Fig.1 PRM750 Sectional View**

## **FOREWORD**

Provided it is correctly installed, aligned and maintained, the PRM750 gearbox should have a long and trouble-free life. This workshop manual contains important instructions to ensure that this is so, and it is of the utmost importance that these are carefully followed. Newage Transmissions Ltd. can accept no responsibility under warranty or otherwise for any loss or damage resulting from failure to observe these instructions.

To avoid prejudicing your rights under warranty, do not undertake any repair or other work on the gearbox during the warranty period without first contacting Newage Transmissions Ltd. or an authorised distributor for advice. In the event of failure, you should do this via the engine distributor who supplied the gearbox, or his local dealer; if this is not possible, you should notify the local Newage distributor/dealer or Newage Transmissions Ltd. direct, quoting the serial number.

## **CLAIMS UNDER WARRANTY**

Claims for replacement of parts under warranty must always be submitted with the gearbox serial number to the distributor who supplied the gearbox; if this is not possible, application may be made to the nearest distributor, who must, however, be advised of the supplier's name and address.

## **SERVICE PARTS**

The comprehensive illustrated parts list gives full information and ordering procedure.

## **PRE-DELIVERY TEST**

Before it leaves the factory, every gearbox is subjected to a final test and inspection which includes the following:-

1. Flush clean.
2. Fill with oil to correct level.
3. Pressurise the case, and check for oil leaks.
4. Check for noise levels.
5. Check for drag in neutral.
6. Check input spline dimensions.
7. Check bolt torques.
8. Check coupling concentricity.
9. Check output nut torque.
10. Check for conformance to customer spec.
11. Record time to working temperature.
12. Record gearbox temperature (Deg. C).
13. Record valve block force N to F (lbf).
14. Record valve block force N to R (lbf).
15. Record oil pressure @ 2000rpm (lb/sq.in) in forward, neutral and reverse.

## IDENTIFICATION PLATE

Every PRM gearbox is fitted with an identification plate on the top half of the gearcase before it leaves the factory; an example of such a plate is shown below.

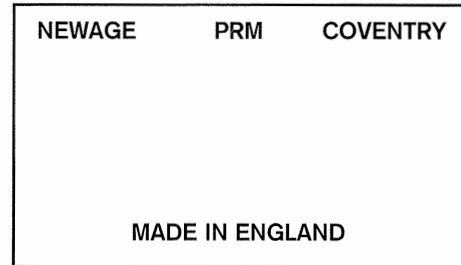
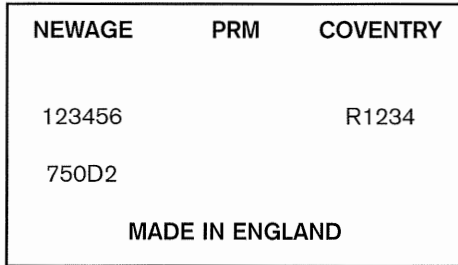

Please complete the above box with serial number and specification of your own gearbox.

It will be noted that there are two lines of numbers.

The top line is the gearbox serial number, and should always be quoted when ordering spare parts; the lower line is the gearbox specification, in the example given this translates as follows:-

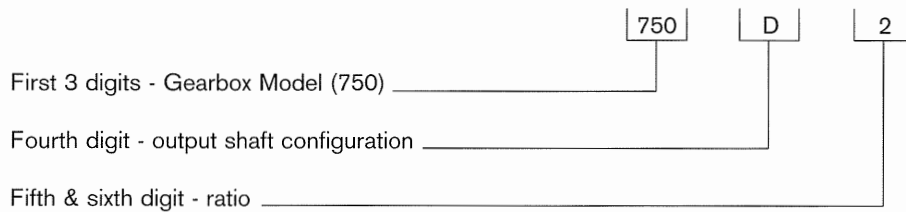

**NOTE:** Throughout this manual, engine, gearbox and propeller rotation are always described as seen looking forward from the propeller to the engine.

## 1. GENERAL DATA

### 1.1 Specifications

Gear ratios

1.09:1, 1.459:1, 1.935:1, 2.565:1, 2.904:1 and 3.952:1

#### POWER RATING - 8° DOWN ANGLE ONLY

GEAR RATIOS	PLEASURE		LIGHT COMMERCIAL		HEAVY COMMERCIAL	
	BHP	kW	BHP	kW	BHP	kW
1.09:1, 1.459:1	9.62	7.17	7.62	5.68	7.23	5.39
1.935:1, 2.565:1	9.48	7.07	7.62	5.68	7.23	5.39
2.904:1	8.00	5.96	7.51	5.60	7.02	5.24

**NOTE:** 8° down angle not available with 3.952:1 ratio

**NOTE:** These powers are expressed in BHP and kW per 100 rev/min engine speed, and are measured at the engine flywheel. Ratings have been established to ensure the long trouble-free life of the gearbox which should not therefore, be used at powers in excess of those shown.

#### POWER RATING - OFFSET AND IN-LINE ONLY

GEAR RATIOS	PLEASURE		LIGHT COMMERCIAL		HEAVY COMMERCIAL	
	BHP	kW	BHP	kW	BHP	kW
1.09:1, 1.459:1	10.52	7.85	8.13	6.07	7.85	5.86
1.935:1, 2.565:1	9.48	7.07	7.85	5.86	7.43	5.55
2.904:1, 3.952:1	8.00	5.96	7.50	5.60	7.02	5.24

**NOTE:** In-line not available with 3.952:1 ratio

**NOTE:** These powers are expressed in BHP and kW per 100 rev/min engine speed, and are measured at the engine flywheel. Ratings have been established to ensure the long trouble-free life of the gearbox which should not therefore, be used at powers in excess of those shown.

Input speed:

Maximum operating speed 4000 rev/min continuous  
4500 rev/min intermittent

### SERVICE CLASSIFICATION DEFINITIONS

**Pleasure:** limited to planing hull pleasure craft with a maximum of 500 hours operating time per year, of which not more than 5% should be at full engine throttle, with the balance of usage at 90% or less of full throttle. The use of PRM marine gearboxes according to this classification in any commercial boat, or in sport-fishing charter boats or long-range pleasure cruisers, is not approved.

**Light commercial:** planing or semi-displacement craft used in pleasure or commercial application may qualify for light commercial rating if annual usage is less than 1500 hours and full throttle operation is limited, with most operating time at partial throttle.

**Heavy commercial:** all displacement and semi-displacement craft used for commercial applications should be classified as heavy commercial duty. In this type of vessel (such as trawlers, purse seiners, lobster and crab boats, tugs, ferries, offshore supply boats etc.) the gearbox is expected to work at full governed engine speed. The power setting of the engine must be known and must be within the permitted heavy commercial rating of the gearbox.



## IMPORTANT NOTE:

1. It is essential that the engine, transmission model, reduction ratio and propeller size are correctly matched so that the engine can attain its rated speed appropriate to the relevant service classification without labouing.
2. It is also necessary to ensure the torsional compatibility of the complete propulsion system from engine through to propeller, since disregarding this may result in gear noise, particularly at low speed operation and may even result in damage to the engine as well as to transmission components.

Newage Transmissions Limited will provide all possible information and assistance to help find solutions to potential torsional problems, but it is the ultimate responsibility of the person assembling the drive and driven equipment to ensure that they are torsionally compatible.

### Input rotation:

May be either clockwise or anti-clockwise (see section 2)

### Output rotation:

Clockwise or anti-clockwise as required (see section 4)

### Approximate weights and oil capacities

DRY WEIGHT			OIL CAPACITY		
PRM750D	72kg (158lb)	excluding drive	2.5 litres	(4.40 pints)	plus the amount
PRM750D4	80kg (176lb)	coupling, adaptor	3.5 litres	(6.16 pints)	needed to fill
PRM750A	90kg (198lb)	and cooler.	3.0 litres	(5.28 pints)	the cooling
PRM750C	93kg (250lb)		3.0 litres	(5.28 pints)	circuit.
Additional weight, power take off: 6.9kg (15.2lb)					

### Operating pressure:

Minimum:- 3000kPa (440 lb/in<sup>2</sup>)  
Maximum:- 3300kPa (485 lb/in<sup>2</sup>) } Oil pressures should be measured at a gearbox temperature of 70°C and an input speed of approximately 1500rpm.

**NOTE:** Pressure may vary at different operating speeds; it is likely that, on start up, when the gearbox is cold, significantly higher pressures may occur.

### Operating oil temperature:

The normal operating temperature should be in the range 50°C to 80°C with a maximum of 90°C permissible for very short periods only.

### Transmission cooling:

An oil cooler is necessary to ensure that correct operating temperatures are maintained and the gearbox is provided with two  $\frac{3}{8}$  inch BSP connectors on the valve block to allow it to be fitted. The size of the cooler depends on a number of factors including the engine horsepower, operating speed, duty cycle, inlet water temperature and ambient temperature.



**CAUTION:** It is important to ensure that any oil cooler used is capable of withstanding lubrication pressures in the order of 2040kpa (300 lb/in<sup>2</sup>). This may be seen on initial start up from cold at maximum engine speed.

Suitable coolers are available from Newage Transmissions Ltd.

### Engine mounting adaptors:

Available in SAE 2,3,4 and Velvet Drive (Borg Warner) specifications. Note: Velvet drive adaptor not available for 3.952:1 ratio.

**Input drive couplings:**

Flexible drive couplings are available to suit flywheels of 10" and 11.5" nominal diameter to SAE J620C, and to other dimensions.

**Gearcase:**

Heavy duty cast iron for use in the marine environment, constructed in two halves for ease of servicing; ribbed internally for rigidity and strength.

**Input shaft:**

750D, 750A: 29mm diameter with  $16/32$  DP 17 tooth involute spline.

750C: 33mm diameter with  $20/40$  DP 26 tooth involute spline.

**Propeller thrust:**

Ahead and astern thrust is carried by output shaft bearings of ample capacity for all Newage approved ratings.

**Output flange:**

152mm (6 in.) diameter, with 6 holes 13mm (0.512 in.) diameter on 121mm (4.5 in.) pitch circle diameter, and female spigot, 76.2mm (3.00in) diameter.

**Installation angle:**

The maximum fore and aft installation angle at rest is 17°.

**BASIC INSTALLATION DETAILS - PRM750**

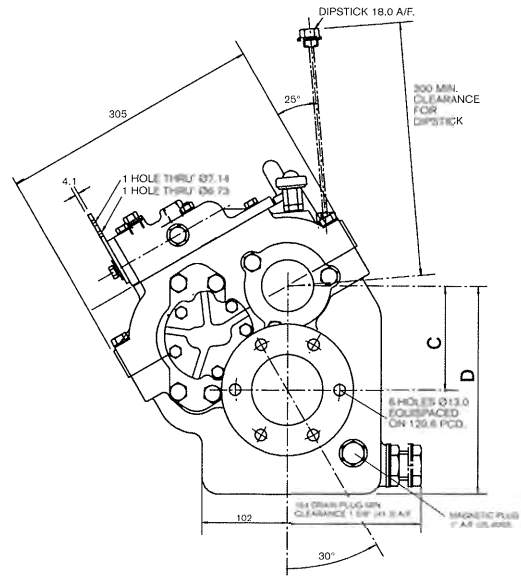
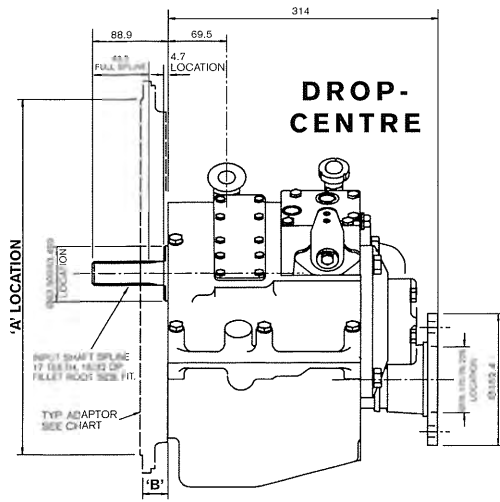

ADAPTORS	Ø 'A'	'B'
	mm	mm
SAE2	447.68	15.88
SAE3	409.55	15.75
SAE4	361.95	19.05
B/W	209.52	28.57

**IN-LINE**

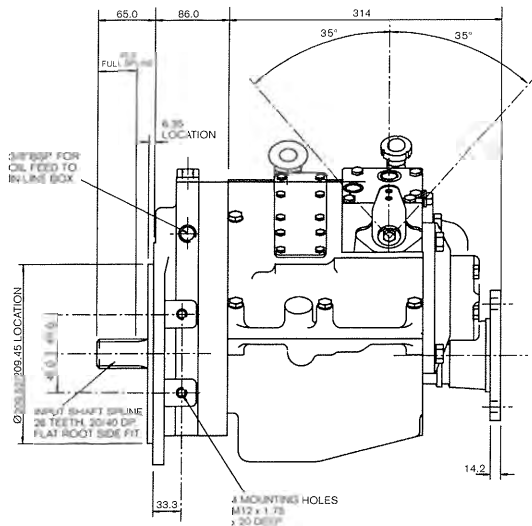

**DOWN-ANGLE**

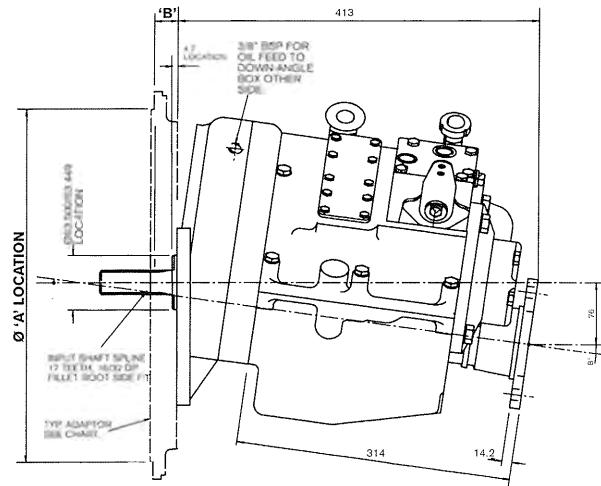

**IMPORTANT NOTE**

All information given in this manual is correct at the time of going to press. However, in the interests of technical progress, design specifications are subject to change without notice. Accordingly, data given herein should be regarded as a general guide only and does not form part of any contract. Any specific performance requirements must be made known to us in writing with customer orders for goods. Illustrations are approximate only and do not form part of any contract with us; certified installation drawings are available on request. All goods are supplied in accordance with our standard terms and conditions of sale.

**INSTALLATION ANGLE**

The maximum fore and aft installation angle permissible at rest is 17°.

Fig. 2

## 2. INTRODUCTION

Newage Transmissions Ltd. PRM750 marine transmission are oil-operated gearboxes of the counter-shaft type with separate oil-operated multi-disc clutches (which need no adjustment) for both ahead and astern drive. This design permits full power to be transmitted in astern as well as ahead, and also allows right-hand or left-hand propeller rotation in ahead drive, with identical ratios in ahead and astern.

The PRM750 can be fitted to both left-hand (anti-clockwise) and right-hand (clockwise) rotating engines (see section 3.3)

**NOTE:** throughout this manual, engine, gearbox and propeller rotations are described as seen when standing behind the boat, i.e. facing forwards towards the transmission and engine.

## 3. CONSTRUCTION

### 3.1 Gearcase

The gearcase has been kept free from hydraulic pipes, cylinders and associated components. The only items mounted externally are the oil pump, valve block, oil cooler and operating lever.

A magnetic drain plug is provided at the rear face of the gearcase; this can be removed if required to allow suitable pipework to be connected to a hand-operated drain pump.

Connections are provided on the valve block for the oil cooler pipes and pressure gauge.

### 3.2 Gear train

The transmission comprises an input shaft assembly, a layshaft assembly and an output shaft.

The input shaft, which is supported by a taper roller bearing at either end, incorporates a drive pinion of the required ratio, running on needle roller bearings, an emergency operating device (see section 6.4), the forward drive clutch assembly (when used with a right-hand propeller), the clutch gear and a hydraulically actuated piston to operate the clutch.

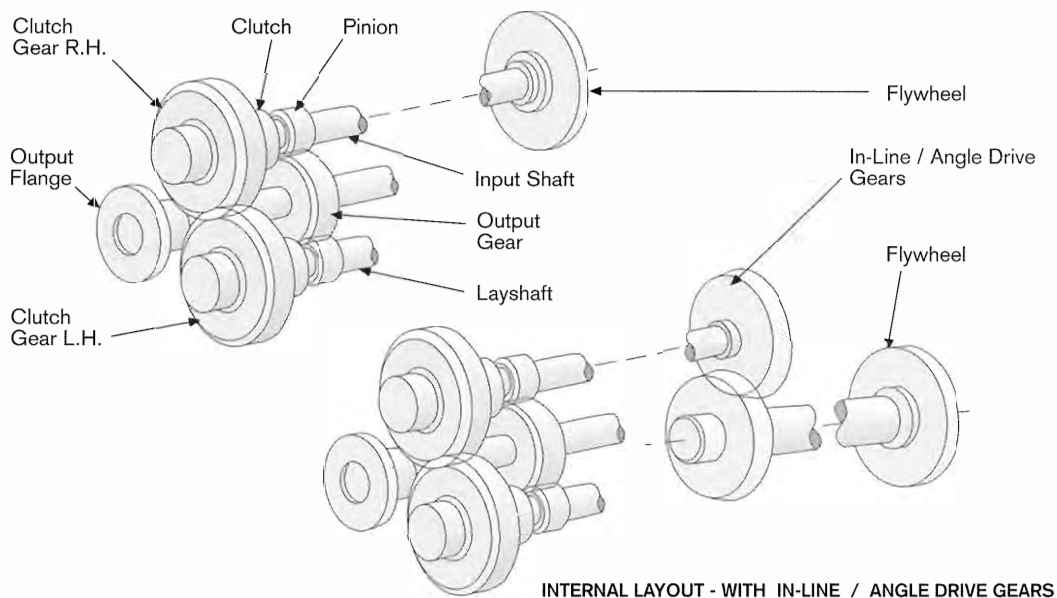

Fig 3. Internal layout, PRM750A/C/D

The layshaft is similarly supported by taper roller bearings and also incorporates a drive pinion of the same ratio, also running on needle roller bearings, the reverse drive clutch assembly (when used with a right-hand propeller), a clutch gear of the opposite hand rotation to that on the input shaft, and a hydraulically actuated piston which operates the clutch.

The output shaft runs on amply proportioned bearings, arranged in such a way that propeller thrust can be satisfactorily absorbed; it also carries the output gear and incorporates the output flange.

### 3.3 Gear train (in-line)

The in-line gearbox incorporates a matching pair of involute gears, arranged so that the input shaft of the main gearbox is stepped down to the same centre line as the output shaft. This brings the propeller shaft into line with the engine crankshaft.

#### 3.3.1 Gear train (angle drive)

The angle drive unit incorporates a pair of conical involute gears (supported on bearings of ample size for all factory approved ratings) arranged so that the output shaft runs at an angle of 8° down relative to the input shaft and reducing the centre line distance between the engine crankshaft and the gearbox output shaft. This allows the engine to be installed as near to the horizontal as possible whilst maintaining the required propeller shaft line.

### 3.4 Oil pump

A cast iron gear-type pump externally mounted at the rear of the gearcase and driven by the layshaft, supplies oil at high pressure for actuating the clutch assemblies, and at lower pressure for lubrication. It should be noted that pressure may vary at different operating speeds. It is also likely that, on start up, when the gearbox is cold significantly higher pressures may occur. (See note on transmission cooling page 8)

When the transmission is used with anti-clockwise engines (looking at the flywheel), or with clockwise engines if the gearbox is a PRM750C/A the oil pump is fitted in its standard position. With clockwise, or anti-clockwise engines for PRM750C/A the pump is turned through 180° (see illustrations).



Fig. 4  
Pump mounting position  
anti-clockwise engines



Fig. 4  
Pump mounting position  
clockwise engines

**NOTE:** Unless otherwise specified at the time of ordering, it will be assumed an anti-clockwise rotating engine is being used and the oil pump will be mounted accordingly.

If a clockwise rotating engine is specified when the order is placed, the pump will automatically be mounted in the appropriate position.

### 3.5 Valve block

The valve block is located on the top of the gearcase and contains the main control valve, integral with which is the high pressure valve controlling the supply of oil to the clutch assemblies. Oil which is surplus to clutch operation requirements is used for lubrication purposes.

The control valve is fitted with a spring-loaded neutral detent which provides a positive neutral position ensuring correct selection of either ahead or astern drive.

### 3.6 Neutral safety switch

A neutral safety start switch, which prevents the engine from being started unless the gearbox is in neutral, is available as an optional extra.

This device is of obvious benefit, since it will help prevent accident or damage caused by a boat moving ahead or astern on engine start-up in a crowded marina or other area. Newage Transmissions Ltd. strongly recommends the use of this device.

When fitted, the switch is located on the valve block (See item C27 on the parts list) and should be wired into the starter circuit as shown in Fig. 5.

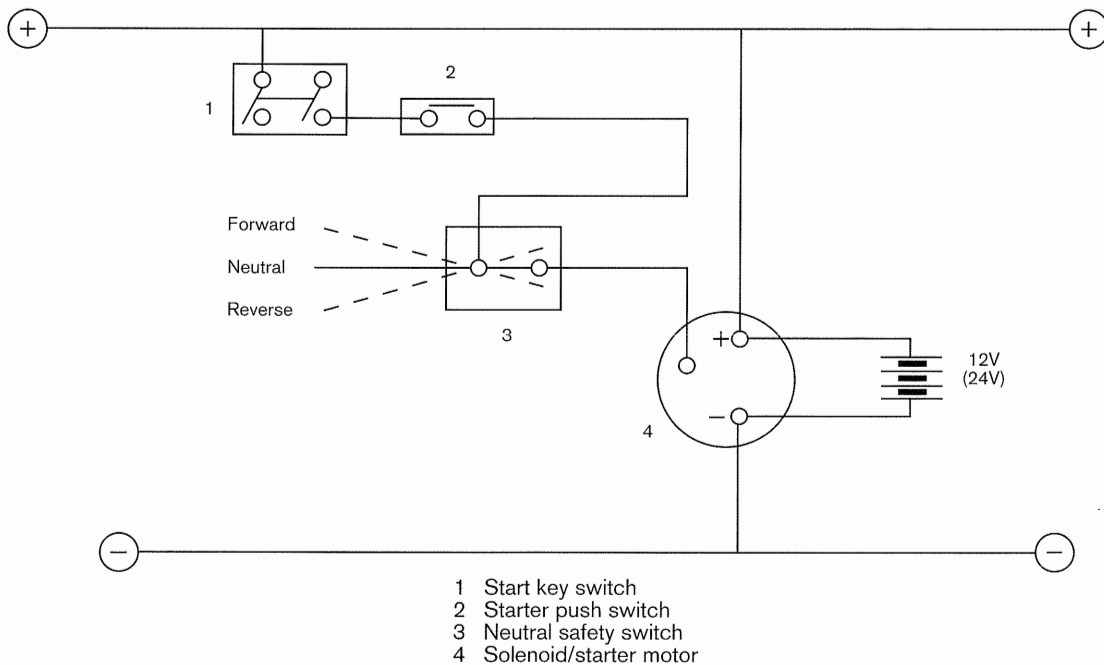

Fig. 5 Wiring diagram, neutral safety start switch

## 4. OPERATING SYSTEM

### 4.1 Output rotations









With the control lever at the mid-point of travel or neutral position and the engine running, the splined input shaft and the clutch gear rotate at engine speed. The clutch gear is in constant mesh with the clutch gear on the layshaft which is therefore also driven at engine speed, but in the opposite rotation. Since neither clutch is engaged, the drive pinions do not rotate.

When the control lever is moved to the 'ahead' position the hydraulic system is actuated and oil is directed at high pressure to the clutch on the appropriate shaft; the clutch engages and engine drive is directed to the forward drive pinion. The pinion turns the gear on the output shaft and the propeller shaft and propeller are rotated in the direction corresponding to ahead movement of the vessel.

Similarly, when the control lever is moved to the 'astern' position, the clutch on the opposite shaft is engaged and drive applied to the reverse pinion. This turns the output shaft gear in the opposite direction; and the propeller shaft and propeller rotate in the direction corresponding to astern movement of vessel.

**NOTE:** the above descriptions are reversed when considering PRM750C in-line unit or PRM750A angle drive unit.

## GEARBOX OUTPUT ROTATION

	Engine rotation anti-clockwise		Engine rotation clockwise	
	PRM750C/A	PRM750D	PRM750C/A	PRM750D
Lever Backward				
Lever Forward				

- NOTE:**
- (i) Rotations are as seen looking from the propeller forward to the gearbox.
  - (ii) Anti-clockwise engines are the most common, and the standard gearbox build therefore assumes an anti-clockwise input.

### 4.2 Hydraulic system

Oil is pumped from the gearbox sump through the internal supply pipe to the control block. This incorporates a high pressure valve which ensures that the correct operating pressure is maintained.

When the operating lever is moved, oil is delivered under pressure to a feeder on either the input shaft or the layshaft and thence to a piston which actuates the appropriate clutch for either ahead or astern drive.

Excess oil is then used for lubricating the gearbox, angle drive, in-line unit and PTO if fitted.

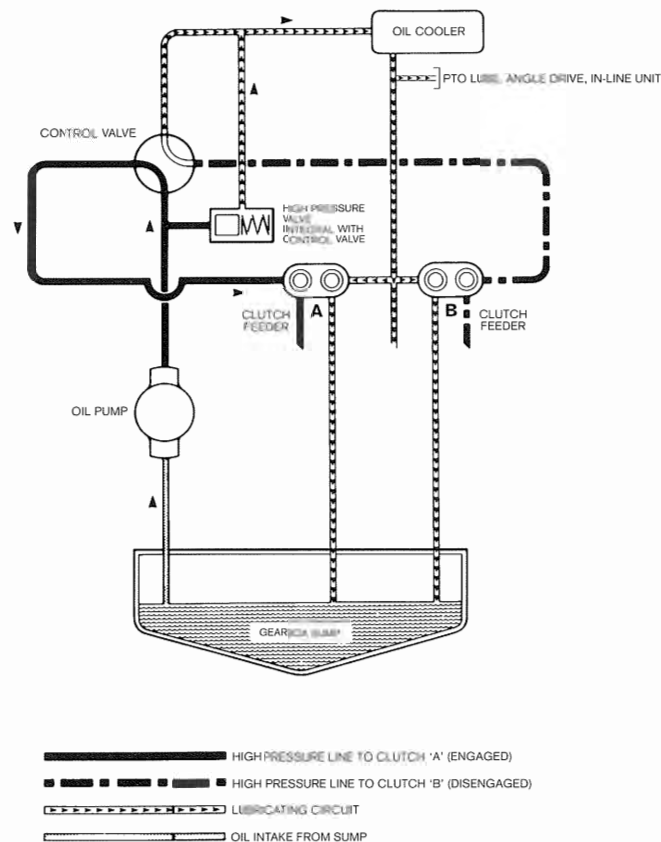

Fig. 6 Hydraulic and lubricating oil circuits

### 4.3 Lubrication

Lubrication oil is delivered via the internal supply to the control block. Irrespective of whether ahead or astern is engaged, oil is diverted from the discharge side of the pressure relief valve to an external oil cooler. After passing through the cooler, the oil is directed through channels in the valve block and thence through the layshaft and drive shaft to lubricate the clutch assemblies.

### 4.4 Approved oils

TEMP	TYPE OF OIL
Below Zero	10W30 or 20W engine oil to API designation CD
0°C to 30°C	10W30 or 15W40 engine oil to API designation CD
Above 30°	10W30 or 40W engine oil to API designation CD
<b>Note: Gearboxes are despatched from the factory without oil.</b>	

It is essential that only good quality engine oil, supplied by a recognised and well known manufacturer, is used in the PRM750. Do not mix different brands, types or grade of oil.

**NOTE:** This oil specification also applies to gearboxes fitted with the electronic trolling valve (available 1996).



**CAUTION:** Failure to comply with the above oil types may result in the forfeiture of warranty cover since no claims under warranty will be entertained if oil of the wrong specification is used.

## 5. INSTALLATION

### 5.1 General

The Newage PRM750 marine gearbox is supplied with a choice of adaptor plates to SAE2, SAE3, SAE4, and Velvet Drive (Borg Warner) specifications enabling it to be fitted to engines having flywheel housings of equivalent specification.

Drive is transmitted from the engine to the gearbox via a flexible centre drive plate (damper plate) which bolts to the engine flywheel. The gearbox input shaft is driven from the centre spline.

These drive plates have a degree of torsional flexibility, the purpose being to reduce engine torsional or cyclic vibrations and prevent them being passed to the transmission.

The strongest engine vibrations are usually those caused by the firing cycle. Diesel engines which have high compression ratios, usually generate stronger vibration pulses than petrol (gasolene) engines; and it is often the case that of two engines of roughly equivalent size, the one having the greater number of cylinders will tend to run more smoothly than the one with fewer cylinders, although this is by no means always the case.

In all marine installations, correct alignment of the engine, gearbox and propeller shaft is extremely important - misalignment can cause noise, vibration and premature failure - and it is strongly recommended that all the procedures detailed in this manual are carefully followed.



**CAUTION:** It is particularly important to ensure the torsional compatibility of the complete propulsion system from engine through to propeller since disregarding this may result in gear noise at low speed operation and in extreme cases damage or failure of components. Newage Transmissions Ltd. will provide all possible information and assistance to help find solutions to potential torsional problems, but it is the ultimate responsibility of the person assembling the drive and driven equipment to ensure that they are torsionally compatible.

### 5.2 Checking the engine flywheel housing

Attach a dial test indicator, calibrated in units of 0.025mm (0.001in.) or smaller, to the flywheel so that the measuring stylus of the indicator is perpendicular to the bore of the flywheel housing (bore A on Fig.7). Rotate the flywheel and check the deviation on the indicator over one complete revolution: this should not exceed 0.152mm (0.006in.) total indicator reading.

With the dial test indicator still attached to the flywheel, re-position the stylus so that it is perpendicular to the face of the flywheel housing (face B on Fig. 7). Rotate the flywheel and check the deviation over one complete revolution; again, this should not exceed 0.152mm (0.006in.) total indicator reading.



### 5.3 Checking the engine flywheel

Attach a dial test indicator, calibrated to 0.025mm (0.001in.) or less, to the engine flywheel housing so that the measuring stylus of the indicator is perpendicular to the bore of the register in the flywheel (bore C on Fig. 7). Rotate the flywheel through one complete revolution and note the deviation, this should not exceed 0.125mm (0.005in.) total indicator reading.

With the dial test indicator still attached to the flywheel housing, reposition the stylus so that it is perpendicular to the face of the flywheel register (D on Fig. 7). Rotate the flywheel through one complete revolution and note the deviation, this should not exceed 0.125mm (0.005in.) total indicator reading.

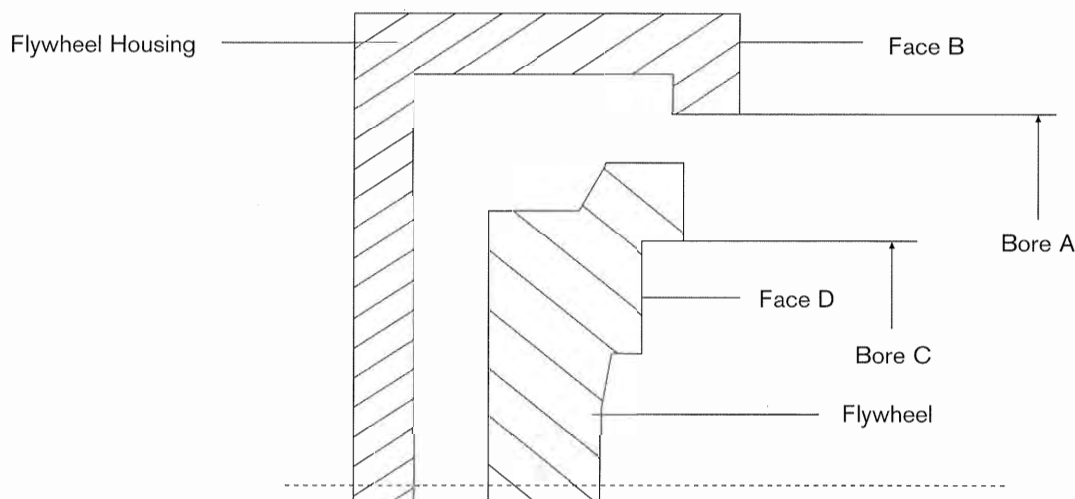

Fig. 7 Checking the flywheel and flywheel housing

### 5.4 Mounting the gearbox to the engine



**CAUTION:** Failure to carry out the following mounting instructions correctly can cause vibration that could result in component or gearbox failure.

1. Taking care to ensure correct alignment, bolt the adaptor flange to the front of the gearbox; the maximum misalignment allowable between the adaptor and the gearbox is 0.002in (0.05mm).
2. Using an alignment mandrel if available, mount and bolt the flexible input coupling to the flywheel via the holes provided. If the flywheel and couplings are to SAE standard, the outside diameter of the coupling should be a close fit in the flywheel register.

If no mandrel is available, tighten the mounting bolts just sufficiently to prevent free movement, assemble the gearbox to the coupling, and rotate the engine two or three revolutions by hand to align the plate. Tighten up two or three opposite bolts, using the inspection window provided in the gearbox adaptor flange.

3. Remove the gearbox and fully tighten the flexible input coupling bolts.
4. Offer up the gearbox and adaptor to the input coupling and engine flywheel housing at the correct attitude to provide the output shaft offset and insert the gearbox input shaft into the centre of the coupling (it may be necessary to rock the shaft slightly to ensure that the shaft enters). Press the assembly fully into position, align the mounting holes in the adaptor flange with those on the flywheel housing and tighten fully. (See torque chart page 40)

## 5.5 Oil Cooler

All Newage PRM750 gearboxes must be fitted with an oil cooler to maintain correct working temperature (50-80°C). To permit a suitable cooler to be fitted, two 3/8 in. BSP connections are provided on the valve block. Note: these are blanked off with plastic "Redcap" plugs on delivery from the factory.



**CAUTION:** Failure to correctly install an oil cooler into the lubrication circuit can result in damage to the gearbox see figs. 8, 9, 10, 11, 12, and 13 for correct circuit. After a gearbox failure it is extremely important to flush cooler and hoses completely to remove any contamination. Failure to do so could result in the new/repaired gearbox failing prematurely.

The gearbox oil cooler is normally mounted on the gearbox adaptor flange or the bulkhead of the boat, and then connected into the cooling system on the engine; one method of arranging the engine and gearbox cooling circuit is shown at Fig. 8.

**NOTE:** cooling water must pass through gearbox cooler before engine cooler.

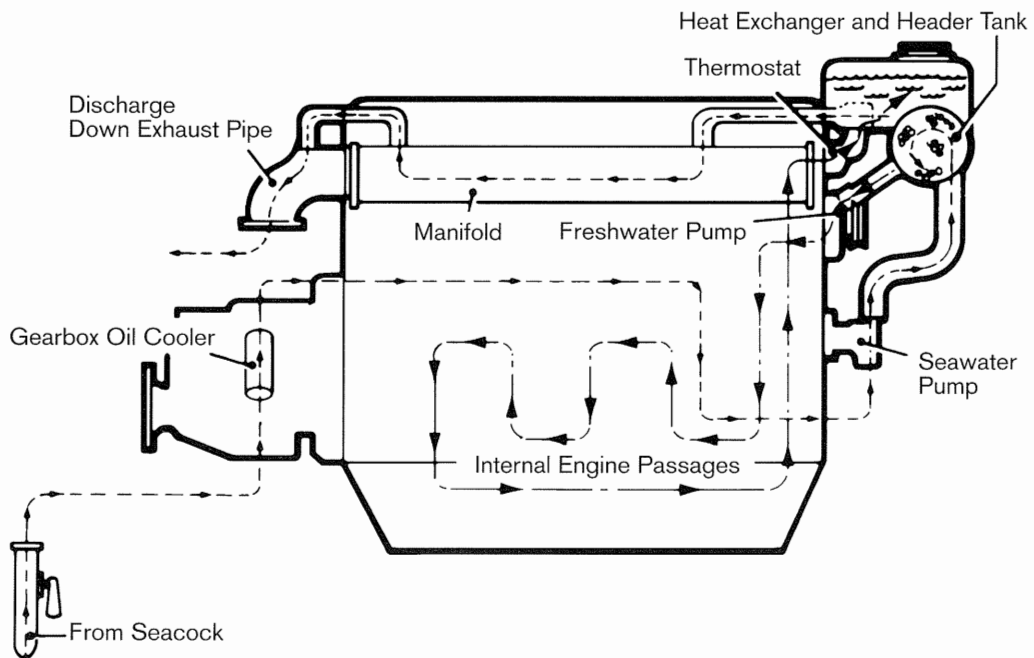

Fig. 8. Engine and gearbox cooling circuit



**CAUTION:** Remove the "Redcap" plugs from the valve block and gearbox prior to the installation of the cooler. Connect suitable hoses to the connections on the oil cooler and valve block, which can then be incorporated into the engine cooling system as outlined at Fig. 8.



**CAUTION:** Operating oil temperature should not exceed 90°C under any circumstances. If the checks listed in the fault-finding chart have been carried out without any fault being found and the gearbox consistently runs at a temperature higher than 80°C, Newage strongly recommends that a larger capacity oil cooler be fitted.

### 5.5.1 PRM750D standard gearbox

Remove the "Redcap" seals from the valve block and, using suitable hoses, connect it to the oil cooler inlet and plumb it into the engine cooling system as outlined at Fig.8.

**NOTE:** Connectors are taper threads i.e. no washers needed.

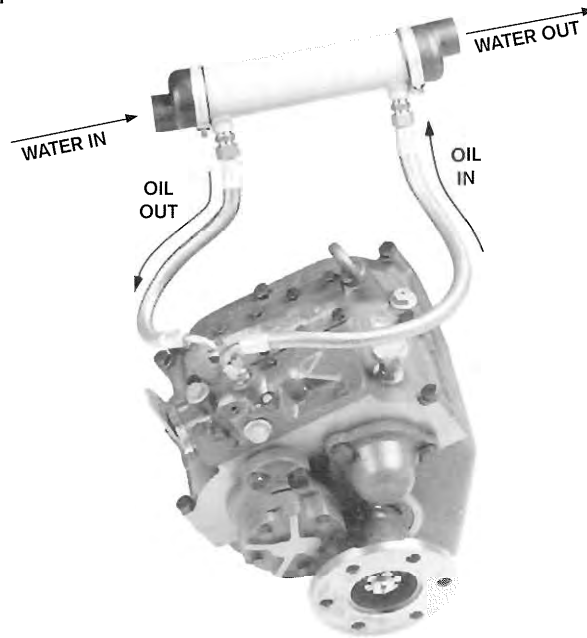

Fig. 9. Oil cooler connections PRM750D

### 5.5.2 PRM750 oil cooler with power take-off

Oil returned from the cooler to the valve block is first passed through the power take-off unit to provide lubrication. The method of connecting the cooling system is as follows:

- a) remove "Redcap" plugs from the valve block.
- b) connect the valve block outlet to oil cooler inlet.
- c) connect the oil cooler outlet to the PTO inlet.
- d) complete the circuit by connecting the PTO outlet to the valve block inlet.

The oil cooler can now be connected to the engine cooling system as outlined at fig. 8.

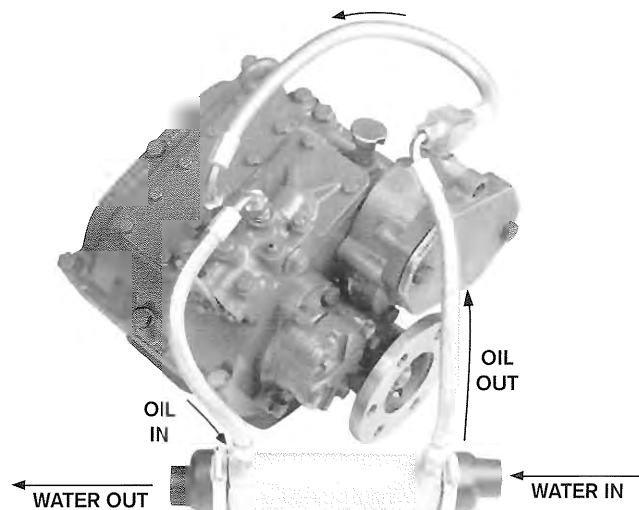

Fig. 10. Oil cooler connections PRM750 with power take-off

### 5.5.3 PRM750A oil cooler with angle drive

Oil returned from the cooler to the valve block is first passed through the angle drive to provide lubrication. The method of connecting the cooling system is as follows:

- remove "Redcap" plugs from the valve block.
- connect the valve block outlet to oil cooler inlet.
- connect the oil cooler outlet to the angle drive inlet.
- complete the circuit by connecting the angle drive outlet to the valve block inlet.

The oil cooler can now be connected to the engine cooling system as outlined at fig. 8.

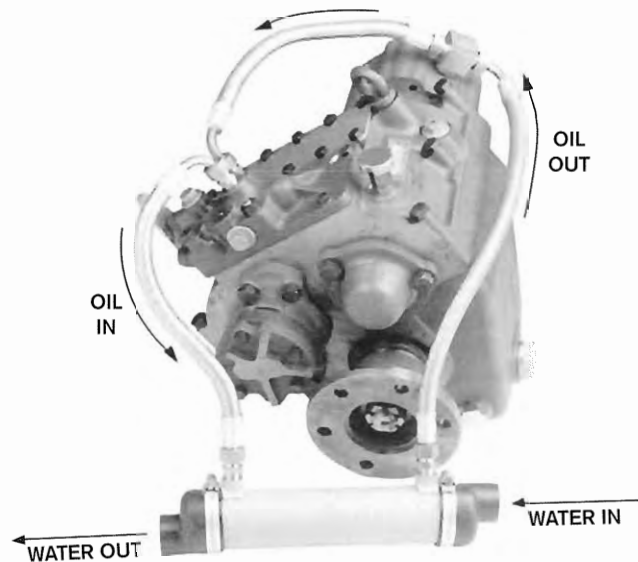

Fig. 11. Oil cooler connections PRM750A with angle drive

### 5.5.4 PRM750C oil cooler with in-line gearbox

Oil returned from the cooler to the valve block is first passed through the in-line unit to provide lubrication. The method of connecting the cooling system is as follows:

- remove "Redcap" plugs from the valve block.
- connect the valve block outlet to oil cooler inlet.
- connect the oil cooler outlet to the in-line inlet.
- complete the circuit by connecting the in-line outlet to the valve block inlet.

The oil cooler can now be connected to the engine cooling system as outlined at fig. 8.

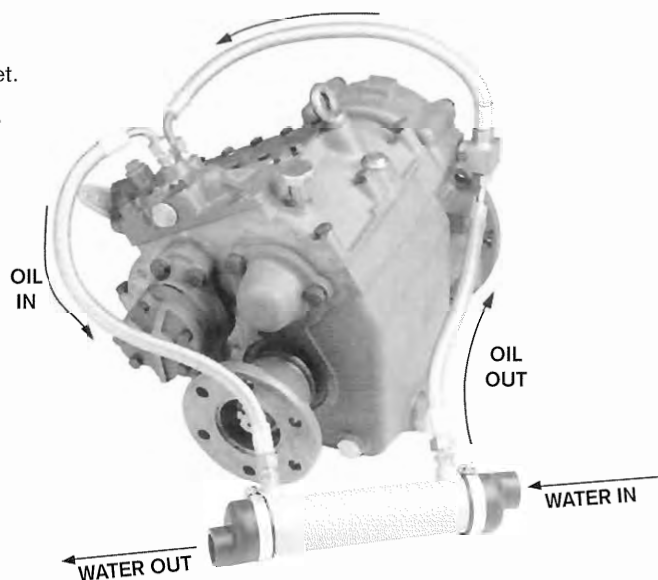

Fig. 12. Oil cooler connections PRM750C in-line

### 5.5.5 PRM750A/PRM750C oil cooler with PTO

Oil returned from the cooler to the valve block is first passed through the PTO and then the angle drive/in-line unit to provide lubrication. The method of connecting the cooling system is as follows:

- a) remove "Redcap" plugs from the valve block.
- b) connect the valve block outlet to oil cooler inlet.
- c) connect the oil cooler outlet to the power take-off inlet.
- d) connect the power take-off outlet to the angle drive/in-line inlet.

**NOTE:** the in-line unit is provided with two connector positions, either can be used to suit installation requirements.

- e) complete the circuit by connecting the angle drive/in-line outlet to the valve block inlet.

The oil cooler can now be connected to the engine cooling system as outlined at fig. 8.



Fig. 13. Oil cooler connections PRM750A/PRM750C with power take-off

### 5.6 Alignment to propeller shaft



**CAUTION:** Alignment between the propeller shaft and the mating flange on the gearbox output shaft is extremely important since excessive vibration and stress may lead to premature failure if correct alignment is not achieved.

In the majority of boats whose hulls are rigid enough to prevent excessive flexing in heavy sea conditions, (which could cause the engine and transmission to shift relative to the propeller shaft), it is generally considered preferable to couple the propeller shaft direct to the gearbox output flange by means of a rigid coupling.

The two main conditions when a flexible coupling should be used are:

- a) in boats whose hulls are not sufficiently rigid to prevent the flexing referred to above,
- b) in cases where the engine is mounted on flexible mounts.

In both instances, the flexible coupling helps to isolate engine vibration or other movement from the propeller shaft thus enabling correct alignment with the propeller shaft and stern tube to be maintained.

Whether a solid or flexible coupling is used, it is extremely important that the following points are carefully checked:

- i) the coupling should be a tight press fit on the shaft and the keyway accurately made to the correct size, and
- ii) the two halves of the coupling should be carefully aligned. This should be done by bringing the two flanges close enough together so that a feeler gauge can be used to check the vertical and horizontal alignment.
- iii) alignment should only be carried out with the boat afloat. The maximum permissible misalignment being 0.05mm.

Since the propeller shaft line is normally fixed in the boat, alignment is usually obtained by adjusting engine mount shims on the mounts themselves.

**NOTE:** Whenever possible, the engine and gearbox should be installed whilst the hull is afloat, otherwise there is a danger of the hull distorting because of insufficient support over its surface. If the engine and transmission are fitted before the hull is in the water, the installation should be very carefully re-checked for alignment after launching.

In designing PRM750, SAE standards were adhered to as far as possible. However, other manufacturers of similar sized transmissions have a different, but common, output coupling spigot, which is not to SAE. This spigot size has become the industry standard and most proprietary flexible output couplings are made to suit.

### 5.7 Installation angle

The transmissions should normally be installed so that the maximum fore and aft angle relative to the water line does not exceed 17° with the boat at rest. Please consult Newage Transmissions Ltd. if installation angles greater than this are required.

### 5.8 Twin installation

The rotation of the propeller, even in a single engine installation, tends to have a slight "turning" effect on the handling of the boat, but this can normally be corrected with very slight adjustments on the rudder.

In twin installations, the turning effect on the handling of the boat will be much more pronounced if both propellers rotate in the same direction. It is therefore desirable that "handed" (i.e. counter-rotating) propellers be fitted. For this reason PRM gearboxes are capable of providing either hand of output rotation with any of the available gear ratios.

It is also preferable for the starboard (right-hand) propeller to rotate clockwise and the port (left-hand) anti-clockwise rather than the other way about. In the latter case, when the propeller blades are at the lowest point of their rotational arc they tend to create a vacuum which affects the other propeller by reducing the flow of water to it. When the boat is making a tight turn with one gearbox in "ahead" and the other in "astern", the thrust side of one propeller will be acting diametrically opposite to the other, causing the boat to be deflected off line which delays completion of the manoeuvre.

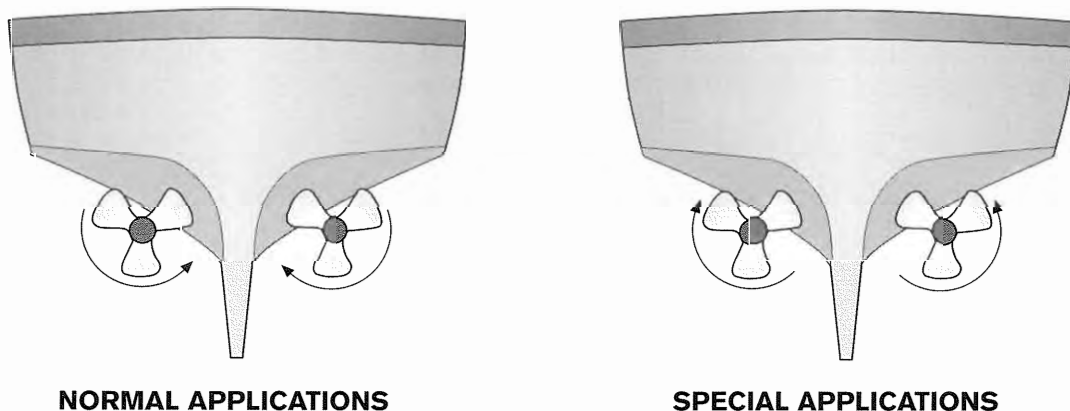
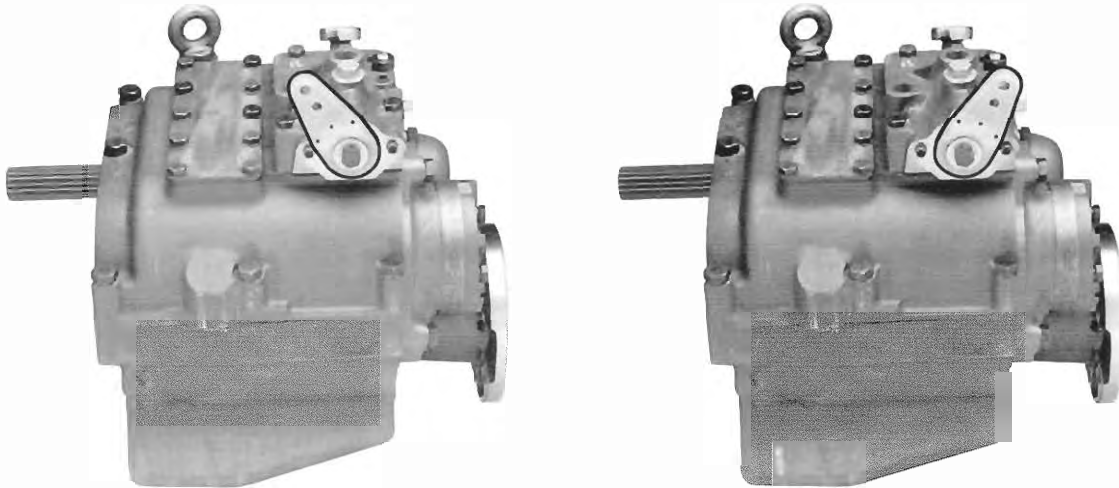

Fig. 14 Propeller rotation twin installations

When connecting remote control units for twin engine/gearbox installations, please remember that moving the gearbox operating lever forwards will produce output rotation as engine (generally left-hand, or anti-clockwise).

Therefore, in order to ensure that the propeller shafts counter-rotate outwards in "ahead", the operating cables should be connected so that the operating lever on the starboard gearbox moves back when the remote control operating levers are in the "ahead" position providing right-hand rotation.



**PORT ENGINE LEVER FORWARD  
LH PROPELLER ROTATION**

**STARBOARD ENGINE LEVER BACK  
RH PROPELLER ROTATION**

**Fig. 15 Operating lever position, twin installations**

### 5.9 Remote control operating systems

The PRM750 can be used with remote control operating systems which links the engine throttle to the gearbox operating lever e.g. Morse Controls single lever type.

The following points should be noted:

- i) The gearbox operating lever is provided with a positive neutral position, which greatly assists the setting up of the remote control unit.



**CAUTION** ii) care should be taken to ensure that the cable moves the gearbox operating lever approximately 2mm short of its maximum forward or backward travel to prevent the lever being brought hard up against the end stop with every gear shift.

The control equipment should in all cases be connected in accordance with the manufacturer's recommendations.

## 6. OPERATION

### 6.1 First time usage



**CAUTION:** Before starting the engine fill the gearbox to the correct level with a suitable oil. (refer to recommended list, section 4.4 page 15)

**NOTE:** screw dipstick fully down when checking oil level.

Ensure the gearbox is in neutral, (it is recommended that the optional neutral safety switch be wired into the starter circuit to avoid uncontrolled boat movement on start up). Start and run the engine for a short time so that the oil circulates through the cooling circuit. Stop the engine and allow the oil to settle, re-check the level and top up to the maximum mark on the dipstick.



**CAUTION:** Using the gearbox with insufficient oil will lead to low pressure, unsatisfactory operation, overheating and eventual failure. Equally, over-filling the gearbox may cause overheating and oil leaks; it is the duty of the owner/operator to make sure that the oil level is correct at all times.

### 6.2 Drive selection

The PRM750 has been designed and tested to ensure rapid shifts from ahead to astern or vice versa and can be operated at full horsepower ratings and speeds. In these circumstances the transmission will respond rapidly.



**CAUTION:** Full power reversals, however, do place abnormal, even if short-lived, loads on the gearbox, and operating life will be prolonged if full power reversals are reserved for emergency only. Newage Transmissions Ltd. recommend that when changing direction the engine speed be brought down to approximately 1000 rev/min. For this reason it is recommended that a proprietary single lever remote control operating system is fitted which links the engine throttle control to the gearbox operating lever.

### 6.3 Trailing (free wheeling) the propeller

The bearings used in the Newage PRM750 gearbox have been carefully selected to ensure that prolonged trailing (free wheeling) of the propeller will not have any detrimental effect on the transmission. This allows the propeller to turn freely with the engine shut down and makes the Newage PRM750 particularly suited for use in auxiliary sailboats, motor sailers or multi-engine installations where the boat may be operated with one or more engines shut down.

It is not therefore necessary to provide any propeller shaft locking device to protect the transmission, although in the case of sailing yachts and other high performance sailboats fitted with two bladed propellers, it may be desirable to fit a propshaft lock so that the propeller can be locked behind the dead-wood to reduce drag.

Where propellers are allowed to free-wheel they can be a useful source of free auxiliary power; if a flat pulley is fitted to the propeller shaft a small generator can be belt driven for charging batteries.



**CAUTION:** Care must be taken not to apply excessive side-load which would cause vibration and misalignment.

### 6.4 Emergency operation

Included as standard in every Newage PRM750 gearbox is a "Get You Home" device allowing the gearbox to be mechanically locked in 'ahead' drive in the unlikely event of hydraulic clutch failure.



**WARNING:** To operate first switch off the engine, select neutral on the operating lever, and disconnect the operating cable, then:

The method of operation is as follows:

1. Remove the 10 top cover securing screws (A7) and the top cover (A6) (located alongside the valve block).
2. Select the shaft which provides the appropriate propeller rotation (see note overleaf) and rotate until a spring clip (A) holding the two screws (B) in position is accessible.
3. Remove the spring clip (A) and tighten the two clamping screws (B), thus mechanically locking the clutch pack in drive. (See drawing pages 48/50 Section D and E)





**CAUTION:** Ensure that sufficient oil remains in the gearbox to avoid further damage and refit the top cover, tighten the bolts to correct torque (see chart page 40)

The engine can now be run, but to minimise the possibility of further damage being caused to the transmission, we recommend that engine speed is limited to  $\frac{1}{3}$  full throttle.

**NOTE:** Assuming an anti-clockwise rotating engine, the shaft to select is:

for left-hand propeller rotation, the left-hand shaft;  
(right-hand shaft for PRM750A and PRM750C).

for right-hand propeller rotation, the right-hand shaft;  
(left-hand shaft for PRM750A and PRM750C).

(as seen looking forward from the propeller to the gearbox).



**WARNING:** When emergency drive is engaged, neither astern nor neutral is available and there is no means of stopping the boat using the gearbox. You must therefore handle the boat with great care, particularly during docking.



**CAUTION:** Disconnection of the operating cable is very important in order to prevent accidental selection of direction whilst the clutch is mechanically locked. After emergency drive has been used, you must seek qualified assistance to check the transmission thoroughly before it is used again. Never use the top cover for topping up the oil.

## 7. ROUTINE MAINTENANCE

### 7.1 Initial maintenance (after 25 hours running)



**WARNING:** Hot oil can cause burns. Do not work on the gearbox with the engine running.

Drain all oil from the gearbox, the magnetic drain plug is located on the rear face of the casing. This requires a 1" A/F spanner to remove, refit drain plug and washer and refill with one of the recommended lubricants (see page 15). Operate the engine and gearbox, allowing the oil to circulate, then stop the engine and allow to settle. Re-check the oil level and top up if necessary to the maximum mark on the dipstick.

**NOTE:** dipstick has to be fully screwed in to check oil level.

### 7.2 Daily checks

1. Check the gearbox oil level.
2. Make visual inspection of the general condition of the transmission and check for oil leaks, especially at the output shaft seal and at gasket sealing surfaces.

### 7.3 Annual check

1. Check oil cooler connections.
2. Check propeller shaft alignment and correct if necessary.
3. Check remote control operating linkage is accurately adjusted to give correct travel on the gearbox operating lever.
4. Check that all fasteners are correctly tightened (see torque chart page 40).

### 7.4 Winter storage

Drain water from the transmission oil cooler to avoid freezing or the collection of harmful deposits.

### 7.5 Other maintenance operations

1. The gearbox oil should be changed at periods which correspond to the intervals at which engine oil changes are carried out.
2. The gearbox oil should also be changed if it has been contaminated by water or if the gearbox has suffered major mechanical damage.

## 8. FAULT FINDING

The following fault finding chart is designed to help diagnose some of the problems which might be encountered. It assumes that the installation and operating instructions in this manual have been followed and we advise that these are checked before proceeding to fault finding.

To avoid prejudicing warranty rights, no repair or other work should be done on the gearbox during the warranty period without first contacting Newage Transmissions Ltd. or an authorised distributor or dealer for advice.

SYMPTOM	CAUSE	REASON	REMEDY
No drive ahead or astern	No oil pressure	Damaged oil pump  Broken input drive plate Broken input shaft Broken output shaft	Remove oil pump and replace complete.  Replace input drive plate. Replace input shaft. Replace output shaft.
Intermittent or complete loss of drive	Oil leaks	Damaged oil seals or gaskets	Check leakage area and replace relevant gasket or seal. Re-fill to correct level on dipstick.
Propeller speed does not increase with engine speed ahead or astern	Low oil pressure to both clutches	Damaged or worn oil pump  Remote control cable not allowing correct gearlever movement Pressure relief valve defective	Replace oil pump complete.  Remove cable and operate lever by hand adjust cable if necessary. Remove valve block and replace spring.
Propeller speed does not increase with engine speed in one direction only	Low oil pressure to one clutch	Piston rings worn Feeder worn  Damaged 'O' ring in hydraulic circuit Blocked hydraulic feed in valve block Damaged clutch plates	Remove appropriate clutch shaft replace worn feeder or piston rings. Check 'O' rings in feeder connectors and piston Remove valve block and examine. Remove and examine appropriate clutch and replace if necessary.
Excessive noise from gearbox at low speeds	Engine idle speed too low  Torsional vibration	Faulty adjustment  Torsional incompatibility of driveline components	Increase idling speed.  If not cured by increasing engine idling speed refer to engine supplier.
Excessive noise throughout operating range	Defective input coupling  Propeller shaft misalignment	Input coupling worn or damaged Hull flexing or faulty installation	Remove, examine and replace input coupling if necessary. Check the alignment of the propeller shaft coupling. If necessary rectify by adjusting shims under the engine mounts or engine mounts themselves.
Excessive vibration throughout operating range	Propeller out of balance  Engine/gearbox misalignment	Propeller damaged or badly machined  Defective bearing	Check pitch, weight, diameter and balance of propeller. Remove transmission and check flywheel face is flat or flexible coupling is correctly aligned. (see section 5.3) Isolate defective bearing and replace.

continued overleaf.

SYMPTOM	CAUSE	REASON	REMEDY
Excessively high oil temperature	Power too high Defective oil cooler or cooler too small Oil level too high/low  Incorrect oil type Defective oil pressure relief valve  Slipping clutches	Incorrect engine rating for gearbox Damaged or blocked oil cooler, incorrectly specified cooler size  Damaged or collapsed relief valve spring Worn clutches, low oil pressure	Re-assess engine power.  Replace oil cooler or re-specify cooler size. Fill to correct oil level on dip stick.  Fill with correct oil type. Remove and examine valve spring. Replace if necessary. Replace defective clutch, see remedy for low oil pressure.
Oil level needs constant topping up	Oil leaks	Defective oil seals, 'O' rings, or gaskets  Defective oil cooler and hoses	Clean the outside of the gearbox particularly around output shaft and valve block, inspect for leaks.  Check for traces of water in the gearbox oil or oil in the cooling water system. Replace cooler or hoses as necessary.
Excessive internal pressure	Escape of pressure from gearbox when dipstick is removed	Defective breather causing leaks past oil seals	Contact distributor or factory for advice.
Difficult to move single lever control	Control lever on valve block too stiff Faulty installation	Defective valve or detent spring  Remote control operating cable badly installed or kinked	Contact distributor or factory for advice.  Check the installation and eliminate all tight bends in the cable.
No neutral	Control system not moving gear lever correctly Seized or dragging clutch	Incorrect control cable set-up  Clutch/es badly worn or seized causing permanent engagement of a direction	Check cable installation.  Check clutch and replace as necessary.



**WARNING:** Before carrying out any service work always ensure that the engine is switched off and disconnect the operating cable from the gearbox.



**CAUTION:** The above operations should be carried out by suitably qualified personnel and strictly in accordance with the procedures detailed in the workshop manual.

## 9. SERVICING AND REPAIRS - GENERAL



**WARNING:** Do not carry out any servicing or repair work without first switching off the engine and disconnecting the control cable.

Before removal of the gearbox for repair or overhaul carefully study the following procedures. Use proper hand tools, slings or hoists for the job - **WORK SAFELY**

Keep all work areas, tools and gearbox clean. Wipe up any spilled oil or fluids to prevent accidents. Wear correct safety equipment i.e. safety glasses and safety shoes to guard against personal injury.

**Remember HOT OIL CAN CAUSE BURNS - WORK SAFELY - USE COMMON SENSE.**

Drawings showing all internal components are contained in the parts lists. (See page 41)

### 9.1 Seals

Remove oil seals carefully to prevent damage if they are to be re-used, however it is best to replace these items. Carefully examine all cast iron piston rings for wear and corresponding wear/damage in the bores. Take care not to break these rings.

## 9.2 Bearings

If removing taper roller bearings for re-use keep them in matched sets and protect all bearings from contamination.

## 9.3 Cleaning



**WARNING:** If using cleaning solvents these can be toxic, flammable, a skin irritant or give off harmful fumes. Avoid prolonged contact, vapour inhalation, or smoking. Failure to take care can result in injury or death.

Rinse all metal parts in solvent to remove dirt, grease and oil.

Be careful to remove solvent from items before re-fitting.

## 9.4 Inspection

### 9.4.1 Gearcase

Inspect for cracks. Check sealing surfaces for any scratches, damage etc. which will lead to oil leaks. Check all threads for damage.

### 9.4.2 Gears

Inspect for any chipped broken or cracked gear teeth, also for any excessive wear, i.e. gear pitting.

### 9.4.3 Bearings

Inspect for any damage, pitting or over-heating.

### 9.4.4 Clutch plates

Inspect all clutch plates for signs of overheating and/or distortion. Check friction surfaces for wear. Replace if oil grooves have worn away.

### 9.4.5 Clutch components

Inspect clutch components for wear, damage, overheating or debris. Check all oil feed holes are clear.

### 9.4.6 Threaded parts

Inspect for stripped or damaged threads.

## 10. SERVICING AND REPAIR PROCEDURES



**CAUTION:** When re-assembling the gearbox all threaded fasteners must be tightened to the torques listed in table page 40, to prevent premature failure.

The servicing, repair and replacement of input shaft and layshaft assemblies and components is simplified by the fact that the gearcase is constructed in two separate halves, the top half being easily removable to give access to the two top shafts.

Some servicing operations can be carried out with the gearbox still mounted to the engine (provided, of course, that the engine compartment is sufficiently large to allow this); examples are the replacement or repair of the valve block and the oil pump. To repair or replace the input shaft, layshaft or output shaft, however, you will need to remove the gearbox from the engine.

If the details outlined below are carefully followed no difficulty will be found in stripping and rebuilding the gearbox. It is most important that all components are perfectly clean and in good condition before re-assembly.



**CAUTION:** The input shaft and layshaft are supported by taper roller bearings. Each time a shaft is stripped for inspection, component repair or replacement it will be necessary to recalculate the number of shims required to load the bearings correctly. Shimming procedures are described in section 10.10.

### 10.1 Valve block

The complete valve block is easily removed for inspection and servicing with the gearbox still in the boat, as follows:-

1. Disconnect the control cable(s) from the lever (C4) on the valve block.
2. Disconnect the oil cooler pipes and the wiring from the neutral switch (C28) if fitted.
3. Remove the 5 bolts (C18/20/26) and one nut (C23) together with washers (C19/24) securing the valve block to the gearcase.
4. To remove the control valve (C11) and piston (C14), simply remove the two cap screws (C6) and withdraw the valves from the valve block (C16).



**CAUTION:** Take care not to lose the detent ball and springs (C12/13).

5. Inspect the seal (C8) seal bore in (C5) and bearing (C10), and replace if worn, damaged or defective. Check that the valve spring (C15) has retained its correct free length (62mm) if not replace it.
6. To assemble and refit the valve block, simply reverse the above procedure. It will be necessary to lightly grease the seal bore (C5) and seal diameter of valve (C11) to avoid damaging the seal (C8) when re-fitting.

### 10.2 Oil pump assembly

The oil pump assembly can be removed with the gearbox in position on the engine.

1. Note the mounting position of the pump (for refitting). (See section 3.4 Fig. 4)
2. Remove the four bolts and washers (A14/A4) securing the oil pump to the main case and withdraw the pump assembly complete with 'O' rings and shims.
3. Inspect the 'O' rings (B6/B7) and replace if necessary. If in good condition store carefully until required for refitting.

If the pump is damaged in any way, the complete pump assembly (B1) must be replaced.



**CAUTION:** If a new pump assembly is fitted the clutch shaft must be reshimmed.  
(See section 10.10)

### 10.3 Oil Strainer

The gearbox oil strainer is attached to the end of the oil suction pump which feeds the pump and is situated in the sump. It may be removed for inspection or cleaning, as follows:

1. Remove the drain plug and washer (A19/A20) in the bottom of the gearbox (rear right hand side), and remove the strainer, which is only a push fit onto the pump suction pipe (B2).

**NOTE:** 1 <sup>5</sup>/<sub>8</sub> inch A/F spanner required.

2. Wash the strainer in a suitable cleaning solvent to remove any debris which may have become attached to it. (See section 9.3).
3. Ensure that the baffle (B5) is correctly located, then refit the strainer.
4. Refit the drain plug and washer in the bottom of the gearcase.

### 10.4 Removing the transmission from the boat



**CAUTION:** Before commencing work see section 9. The following instructions must be complied with to avoid damage to the gearbox.

1. Ensure that the gearbox operating lever (C4) is in the neutral position, disconnect the operating cable or cables, and the wiring from the neutral safety switch, if fitted.
2. Drain the gearbox oil into a suitable container and disconnect the oil cooler pipes.

3. Unscrew and withdraw the bolts connecting the gearbox output flange from the flexible coupling or mating half coupling on the propeller shaft.



**CAUTION:** Sling ropes around the gearbox securely to provide support  
**WARNING** while it is being removed from the engine.

4. Remove the bolts securing the adaptor flange to the flywheel housing.
5. Slacken the bolts which secure the flexible drive coupling to the flywheel.
6. Withdraw the gearbox, if necessary rocking the unit slightly in order to disengage the input shaft spline from the internal spline in the coupling, and lift clear.

### 10.5 Removing the input shaft and layshaft assemblies

1. Remove the gearbox from the boat as described in section 10.4.
2. Undo the 4 bolts (A14) securing the oil pump and withdraw the oil pump, shims and 'O' rings, noting the position of the pump for refitting. (Note: keep the pump shims with the pump assembly).
3. Remove the 3 bolts (A11) securing the shaft end cover (A10) and remove. (Note: keep the shims and 'O' rings with the cover).
4. Remove the 5 bolts (C18/20/26) and 1 nut (C23) retaining the valve block and remove it.
5. Remove the 7 bolts and washers (A3/A4) securing the gearcase top half (A1) and lift clear.
6. Lift the input shaft assembly, front seal housing (D2) and thrust washer (D4) from the gearcase.
7. Lift the layshaft assembly and front end cover (E2) from the gearcase.

### 10.6 Servicing input shaft and layshaft assembly components

See pages 48/50 for assembly drawing.

#### 10.6.1 Input shaft oil seal

In the event of an oil leak caused by a damaged seal, remove the input shaft oil seal housing (D2) from the shaft and, using a hardwood drift and hammer, remove the seal from the housing.

Fit a new seal (D1) in the housing (D2) and refit the housing.

#### 10.6.2 Drive end bearing

To renew a damaged or worn bearing:-

1. Support the relevant shaft in a vice and remove the oil seal housing (D2) (this applies only to the input shaft).
2. Using a pulley extractor with its jaws located behind the pinion, withdraw the clutch pinion (D9/E7), thrust washer (D6/E4), thrust bearing (D7/E5) and end bearing (D5/E3). Check that needle bearings (D10/E8) and spacers are in good condition.
3. Refit the needle bearings, spacers and clutch pinion to the shaft.
4. Replace the thrust washer and thrust bearing, inspecting for wear and replacing where necessary.
5. Locate the new bearing (D5/E3) on the shaft and, using either a hand press or a hardwood drift and hammer, gently drive the assembly into position. Take care not to damage the bearing rollers or raceways during this operation.

**NOTE:** if the bearing is correctly located a small amount of pinion end float will be detected i.e. between 0.13 to 0.45mm.

6. Reposition the oil seal housing (D2) on the shaft (input shaft only).

**NOTE:** if new bearings are fitted, they must be re-shimmed as described in section 10.10.

### 10.6.3. Clutch assemblies

Clutch plates which have discoloured and/or distorted by overheating or if the groove pattern on the friction plates have been worn away they need to be changed as follows, these instructions apply to both directional clutches:-

1. Remove the drive pinion (D9/E7) and bearing (D5/E3) as previously described in section 10.6.2.
2. Remove spacer, needle roller bearing, spacer, needle roller bearing.
3. Remove the large circlip (D15/E13).
4. Withdraw the complete clutch assembly from the shaft noting the position of the pull off springs and clutch pins.
5. Remove the small snap ring (D12/E10), thrust bearing, and thrust washer and inspect for wear or damage and replace where necessary.

To rebuild the clutch assembly, the procedure is as follows:

6. Position shaft upright and locate the 3 clutch pins (D18/E16) into the clutch gear (D31/E29).
7. Replace thrust washer, thrust bearing and the small snap ring.
8. Fit the clutch end plate (D21/E19) into the clutch gear and fit pull-off springs over the clutch pins. Then, starting with one of the driver clutch plates (D20/E18) build up the replacement clutch onto the clutch end plate.
9. Replace the clutch end cover (D16/E14) onto the clutch pack, locating the 3 pins and ensuring that one of the tapped holes in the clutch end plate aligns with the dimple on the body of the clutch gear.
10. Replace the large circlip.
11. Replace the drive pinion into the clutch pack until it touches the thrust bearing.
12. Replace needle roller bearing, spacer, needle roller bearing and spacer.
13. Replace the thrust bearing, thrust washer and bearing inner cone on the shaft and gently drive the bearing into position.

### 10.6.4. Clutch gear

It is recommended that the clutch gear (D31/E29) is not separated from the shaft (D32/E30) unless either is damaged; if it is necessary to split them, this can only be accomplished by means of a power press, as follows:

1. Position the shaft assembly so that the front face of the clutch gear is supported face downwards on a plate, and press the shaft out through a suitable hole in the plate.
2. The clutch gear, piston (D23/E22), feeder (D27/E25) and rear end bearing (D26/E24) will now be free for inspection and replacement if necessary.

To re-assemble:

3. Fit new 'O' rings (D22/D24)(E20/E21) and insert the piston into the clutch gear.
4. Fit new piston rings (D30/E28) to the feeder (for piston rings and feeder removal refer to section 10.6.6). Refit the clutch gear to the feeder, and replace the assembly on to the shaft. Ensure that the spline on the shaft has engaged with the clutch gear.
5. Place the rear end bearing on to the shaft and gently drive into position.
6. Replace the clutch as described in 10.6.3.



**CAUTION:** It is advisable to renew both clutch gears together as damage to one often results in damage to its mating gear. It is also strongly recommended that piston seals and tab washers are also replaced.

### 10.6.5 Drive pinion

It is advisable to renew both drive pinions together if one is worn or damaged. To ensure that the drive pinion of the correct ratio is used please refer to the parts list page 49/51. If a different ratio from that originally supplied is required, the output gear as well as both pinions will need to be changed.

To replace the drive pinion, follow the procedure set out in section 10.6.2

### 10.6.6 Rear end bearing, piston rings and feeder

1. Place the shaft assembly in a vice so that the front face of the clutch gear is face down, using a pulley extractor with the jaws located underneath the feeder, pull off the rear end bearing (D26/E24) together with the feeder (D27/E25). This provides access to the piston rings and feeder.
2. Remove the pistons rings from the shaft with the aid of a special piston ring extractor or a piece of thin steel. Raise one end of the top ring out of the groove and insert the steel strip between the ring and the shaft. Rotate the strip around the shaft applying slight forward pressure to the raised portion of the ring until it rests on the land above the groove, where it can be eased off. Repeat this with the other two rings.
3. Take out the new rings from the packing and clean off any grease or inhibitor.
4. If a ring loading tool is available, fit this around the shaft, load the rings onto the tool and locate in their approximate position. Gently withdraw the tool and allow the rings to locate in their respective grooves.
5. Where a loading tool is not available use a thin metal strip, long enough to lay along the shaft above the grooves. Expand each ring just sufficiently to allow it to be placed in its approximate position over the strip. Gently withdraw the strip and locate the rings in their respective grooves (see Fig. 16).
6. Compress each ring in turn and carefully fit the new feeders and bearing onto the shaft, and gently drive the bearing into position.

**NOTE:** It is advisable and strongly recommended that piston seals and tab washers should always be replaced.



Fig. 16. Piston ring fitting procedure

### 10.7 Replacement of input shaft and layshaft assemblies

1. Having fitted a new 'O' ring (D3) and oil seal (D1), position the input shaft assembly in the gearcase, ensuring that the thrust washer (D4) is correctly located in the groove in the lower half of the gearcase, and that the seal housing (D2) is correctly positioned.
2. Position the layshaft in the gearcase, fit a new 'O' ring (E1) into the end cover (E2) and carefully position the end cover in the groove in the lower half of the gearcase.
3. Fit two new 'O' rings (D29/E27) to each feeder connector, then coat the mating surfaces of the two case halves with a jointing compound. Pass a length of wire through the holes in the top half of the gearcase into the feeder connectors to ensure that they are correctly located, and fit the top half of the gearcase to the lower.
4. Replace the two front gearcase bolts and ensure the gearcase halves are square.
5. Replace the remaining gearcase bolts and tighten them to the correct torque. (See torque chart page 40)
6. Replace the 'O' ring (A21) in the input shaft end cover (A10), shim, and refit.
7. Replace the three oil pump 'O' rings (B6/B7) then shim and refit the oil pump ensuring that it is fitted in the correct position for the hand of engine rotation required. (See section 3.4)
8. Using a new gasket (C17), refit the valve block.
9. Carefully ensuring correct alignment (section 5.4), refit the adaptor plate to the gearbox, tightening the bolts to the correct torque. (See torque chart page 40)
10. Offer up the gearbox and the adaptor plate to the engine, locating the input shaft in the centre of the coupling, and secure.
11. Reconnect the oil cooler pipes and control cables.

**NOTE:** Shimming procedures are described in section 10.10



## 10.8 Servicing the output shaft assembly

Removal of the output assembly will necessitate removing the gearbox from the boat (see section 10.4). Then proceed as follows:-

1. Remove input shaft and layshaft assemblies as described in section 10.5.
2. Undo the output coupling nut (F14) and remove the coupling (F13) washer (F12) and 'O' ring (F11).
3. Remove the 8 screws and spring washers (F15/F16) and oil seal housing (F8).
4. Extract the Shamban seal (F1) from the front of the output shaft by punching a hole in it and levering out taking care not to damage the casing bore where it fits.
5. Undo locknut (F2) and remove. Prevent output coupling from rotating to help this operation.
6. To remove the output shaft from the gearbox, drive or press on the front end, allowing the rear end bearing (F7) to be removed leaving the front bearing (F3) spacer (F4) and output gear behind.
7. Remove circlip (F17) front bearing (F3) spacer (F8) and output gear (F5). The front bearing can be easily removed by careful use of a drift and hammer.
8. Inspect all bearings for wear or damage, replacing where necessary.



**CAUTION:** The output thrust bearing assembly (F7) is supplied as a pre-adjusted unit, therefore if either bearing is worn or damaged, the complete assembly must be replaced.

9. If either of the thrust bearings (F7) is worn, remove both outer races, the spacer (F18) and shim washer (F19).
10. Wear on any of the output shaft bearings may also result in damage to the output gear (F5) and mating pinions (D9/E7). All these components must be carefully examined and replaced if necessary.

## 10.9 Re-fitting the output shaft assembly.

1. Support the gearcase on the bench, front face down. Place the output gear into position in the casing.
2. Fit the output bearing assembly (F7) onto the output shaft.
3. Feed the output shaft through the gearcase and output gear.
4. Fit seal housing (F8) complete with new 'O' ring (F10) and shaft seal (F9). Tighten screws to correct torque. (See chart page 40)
5. Lightly smear seal diameter of output coupling (F15) with clean grease to aid seal bedding in.
6. Fit washer (F12) 'O' ring (F11) and locknut (F14).
7. Fit spacer (F4) and front end bearing (F3) by gently tapping in with drift and hammer.

**NOTE:** Apply clean grease to rollers to aid assembly.

8. Fit circlip (F17) apply Loctite 270 to locknut (F2) and fit to shaft.
9. Tighten both shaft locknuts to 340 Nm (250lbft)

**NOTE:** It will be necessary to fix the output coupling securely whilst tightening the locknuts.

10. Fit new front seal (F1) dry, and press flush with the gearbox face.

## 10.10 Shimming procedures

The allowable end float on the taper bearing is 0.03 - 0.08mm (0.001 - 0.003in) clearance: this should be checked with the aid of a depth micrometer as follows:

1. Press the bearing outer cup firmly into position and measure between the face of the gearcase and the top of the bearing outer as shown in Fig. 17.
2. Measure the depth of the recess in the oil pump and in the output shaft end cover as in Fig. 18, and make up the difference between the two dimensions with shims.

If no depth micrometer is available, the following method may be used:-

1. Remove the 'O' ring from the oil pump or end cover.
2. Fit enough shims to cause the oil pump or end cover to stand proud.
3. Rotate the shaft, slowly tightening the securing bolts until the shaft starts to bind. Use feeler gauges or shims around the pump or end cover (Fig. 19) to ensure that the gap is uniform and that they are positioned squarely on the rear face of the gearcase.
4. Measure the gap by means of feeler gauges or shims, and deduct shims to this figure plus 0.075mm (0.003in) from the shims already installed.
5. Remove the requisite number of shims, tighten the oil pump or end cover, and test by rotating the shaft.
6. Remove the oil pump or end cover and refit with the 'O' ring installed.

**NOTE:** Shims are available in two thicknesses, 0.254mm (0.010in) and 0.05mm (0.002in). As an example of their use, if an end float reading of 0.584 (0.023in) is obtained, use two shims of 0.254mm (0.010in) and one of 0.05mm (0.002in), giving a final end float or clearance of 0.025mm (0.001in).



Fig. 17



Fig. 18



Fig. 19

## 11. POWER TAKE-OFF UNIT

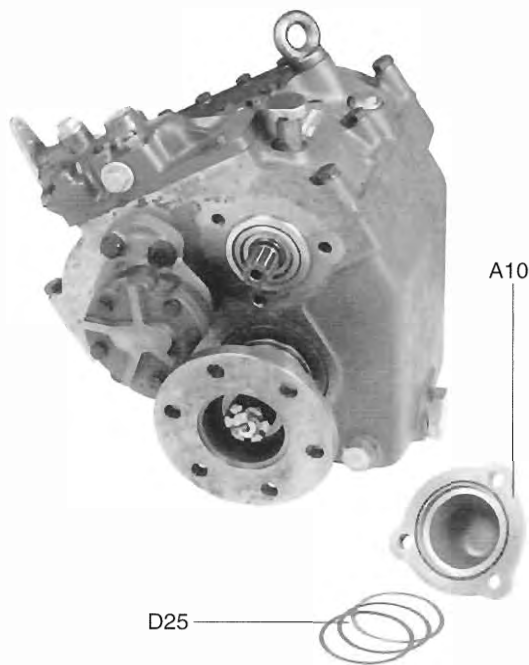

Fig. 20

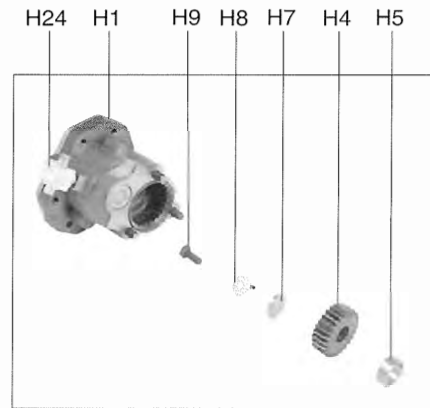

Fig. 21

### 11.1 To fit a P.T.O. unit to an existing gearbox

1. Remove end cover (A10) from rear face of gearbox, taking care not to lose shims. Replace the shims against the bearing outer race. (Use grease if required).
2. Fit spacer (H5) and drive gear (H4) to end of splined shaft, which protrudes from the rear of the gearbox.
3. Fit the spacer (H7) into recess in the gear and the locking tab into the hole in the face of the gear.
4. Tighten screw (H9) to 48Nm (35.5 lbf.ft) and bend up the locking tab.
5. Pass the P.T.O. unit over the gear (H4) and push against rear face of the gearbox, ensuring that shims do not drop down and are located in recess in P.T.O. housing. Also ensure that the 'O' ring remains in the groove in the P.T.O. housing and does not become trapped.
6. Tighten bolts (H11/H20) into rear face of gearbox to 98 Nm (72.5 lbf.ft).
7. Fit oil pipe assembly (H23) as shown on the installation drawing, between the tee piece on the P.T.O. housing and the connector on the valve block.
8. Fit hydraulic pump to P.T.O. unit.



**CAUTION:** The P.T.O. shaft rotates opposite to the gearbox input shaft.

### 11.2 To repair an existing P.T.O. unit

1. Removal of the unit is the reverse of that described in (11.1) above.
2. The output gear assembly (H2) can be removed without removing the P.T.O. unit from the gearbox. Remove hydraulic pump from P.T.O. and slacken screws (H19/H20). Pull out housing (H13) and the gear (H2) (bearing assembly will remain with the housing).
3. To remove the output gear, (H2) remove circlip (H21) and tap gear on the end face to remove from bearing (H12).
4. The bearing (H12) can be removed by removing circlip (H15) and pressing or drifting out bearing.
5. If needle bearing (H3) is worn or damaged, it is best replaced when the P.T.O. housing is removed from the gearcase.
6. If the drive gear (H4) is removed from the gearbox shaft, then tab washer (H8) MUST be replaced.
7. Assembly is the reverse of all that described in 11.2 above.

## 12. 8° DOWN-ANGLE DRIVE UNIT (MT0210)

### 12.1 Retrofitting to an existing PRM750

1. Drain all oil from the gearbox, remove it from the engine, and take off the adaptor plate as previously described. (See Section 10.4)
2. Remove and discard the output shaft front seal (F1) and the input shaft seal housing (D2) from the main gearbox.
3. Remove and discard the transit washer and screw (G25/G26) retaining the angle drive rear spacer.
4. Spacer (G11) included in kit, is **not** required when fitting angle drive to PRM750.
5. Fit the location ring (G8) supplied with the angle drive in the front bore of the main gearbox (i.e. in place of the input shaft seal housing (D2)).
6. Taking care not to damage or lose the shims or 'O' rings, remove the oil pump from the gearbox, rotate it through 180° and bolt it back in position, ensuring that the 'O' rings are correctly located in the grooves and that the shims are properly seated in the pump recess.
7. Position the gasket (G9) on the front face of the main gearbox and offer the angle drive up to the gearbox. Insert the gearbox shaft into the splined gear and fit the bolts (G10/G12), tightening them to the required torque. (See torque chart page 40)
8. Screw the metering union (G23) into the top of the angle drive, fit the tee piece (G21) and connect the oil pipe (G20).
9. Connect the other end of the oil pipe to the low pressure fitting on the valve block.
10. The adaptor plate can now be fitted to the front face of the angle drive. Tighten the bolts to the required torque. (See torque chart page 40)
11. The complete gearbox/angle drive assembly may now be mounted on the engine as described in section 5.4. (See section 5.5.3 for cooling circuit)

**NOTE:** Fitting an angle drive causes the gearbox output rotation to be reversed relative to the movement of the operating lever. (See sections 3.4 and 4)

### 12.2 Replacement of the angle drive gears and bearings

1. Remove the unit from the main gearbox; the procedure is the reverse of that described in section 12.1.
2. Remove the bolt (G3) and insert M8 withdrawal screws in holes adjacent to dowls in rear case to split the 2 halves of the gearcase.
3. Remove the input seal housing (G17) and shims, and the location ring (G8) and shims at the rear face of the output gear.

**NOTE:** Take care not to mix the input and output shims.

4. All bearings and gears may now be inspected; if any one bearing is damaged or worn, it is recommended that all four be replaced, also inspect the gears. If either gear has to be replaced, replace both.
5. The bearing outer races are easily removed from the housing, but a bearing puller will be required to remove the inner races from the gears.

### 12.3 Re-assembling the angle drive

1. Press the bearing inner races to the gears and push the outer races into the halves of the housing.
2. Locate the input gear (G14) in the rear half and the output gear (G5) in the front half of the gearcase.
3. Coat the mating faces with "jointing" compound and bring the two halves together, ensuring that the dowels (G6) are correctly located.
4. Tighten the bolts (G3/G12) to the correct torque. (See torque chart page 40)

### 12.4 Shimming the angle drive input shaft bearings

**NOTE:** Shimming is best done prior to fitting the oil seal (G18) and 'O' ring (G16) and with the unit placed horizontal on a flat surface.

1. Push in the seal housing (G17) against the bearing outer race.
2. Seat the bearings by applying hand pressure to the spacer or placing a weight of approximately 5Kg on top of the spacer and turning the shaft.
3. Using a depth micrometer or a vernier gauge, measure the step between the gearcase face and the lower face of the housing.
4. Lift out the housing and place shims to the value found in 3. under it. End float to be 0.00 - 0.08mm (0.00 - 0.003inches).
5. Fit the seal and 'O' ring to the housing and replace.

### 12.5 Shimming the angle drive output shaft bearings

1. As with the input shaft, apply hand pressure or a weight to the spacer (G8) which is already located in the bore.
2. Rotate the shaft to seat the bearings, and, using a depth micrometer or vernier gauge as before, measure the gap between the face of the gearcase and the face of the spacer which is just below it.
3. Lift out the spacer, insert shims to the value measured in 2. above and replace end float 0.00 - 0.08mm (0.00 - 0.003inches).

The procedure for refitting the angle drive to the main gearbox is as described in section 12.1.

## 13. IN-LINE GEARBOXES

Unlike the angle drive unit, the in-line unit is a factory fitted item and CANNOT be retro-fitted. Servicing the in-line unit is as follows:

### 13.1 Removing the in-line unit

1. Drain all oil from the gearbox and remove it from the engine as described in section 10.4.
2. Disconnect the oil pipes connecting the in-line unit to both the cooler and the main gearbox.
3. Remove the bolts (K21 - 3 off), (K23 - 2 off) and (K24 - 2 off), and split the unit into two halves.
4. The two gears (K7 and K14) can now be removed from the rear half.
5. To detach the rear case half from the main gearcase, remove the cap screw (K15) and four bolts (K17).



**CAUTION:** Take care not to misplace the spacer and shims from either shaft.

### 13.2 Removal of in-line unit components

1. Once the in-line unit has been taken apart as described in 13.1 all bearings and gears are free for inspection for damage or wear. If one gear requires replacing it is advisable to replace both.
2. The bearing outer races can be easily removed from the housing, but a bearing puller or press will be required to remove the inner races from the gears.

### 13.3 Shimming the in-line unit

Before the in-line unit can be reassembled and refitted to the main gearbox, it is essential that the two shafts be shimmed. The procedure is as follows:

1. Push the bearing outer races into the in-line case halves and fit the bearing inner races on to the gears and shafts.
2. Fit the two case halves together and secure with bolts (K21/K24).
3. Using a depth micrometer measure the depth from the front face of the main gearcase to the thrust washer on the input shaft.
4. Ensuring that the outer races of the two rear bearings are correctly located in the rear half of the in-line case measure the distance from the bearing to that rear face.
5. Subtract the value of 4. from 3. the result is the thickness of the shims required. Shimming tolerance is 0.00 - 0.05mm (0.000 - 0.002 inches).
6. To shim the main gearbox output shaft, place the spacer (K12) in the output shaft bore of the main gearcase and using a depth micrometer, measure the distance from the front face of the main gearcase to the face of the spacer.
7. With the lower rear bearing outer race correctly located in the rear case of the in-line unit, measure the step between the face of the rear case half and the outer race seated in the bore.
8. The result of 6. plus 7. is the value of the shims required. Shimming tolerance is 0.00 to 0.05mm (0.000 - 0.002 inches).

### 13.4 In-line unit rebuild

Once the shimming process is completed the in-line unit can be refitted to the main gearbox as follows:

1. Position shims to the correct thickness in both the input and the output shaft bore of the main gearcase.
2. Fit the spacer (K12) in the output shaft bore of the main gearcase.
3. Offer the rear half of the in-line unit complete with outer bearing races to the main gearcase and secure with bolts (K17) and cap screw (K15).
4. Refit the two gears (K7 and K14) together with the bearing inner races, into the rear half of the in-line unit.
5. The front case half and bearing cups can now be secured to the rear half using bolts K21, K23 and K24.
6. Taking care not to damage it, press the oil seal (K22) into the bore.
7. Reconnect the oil pipes to the cooler and the main gearbox.



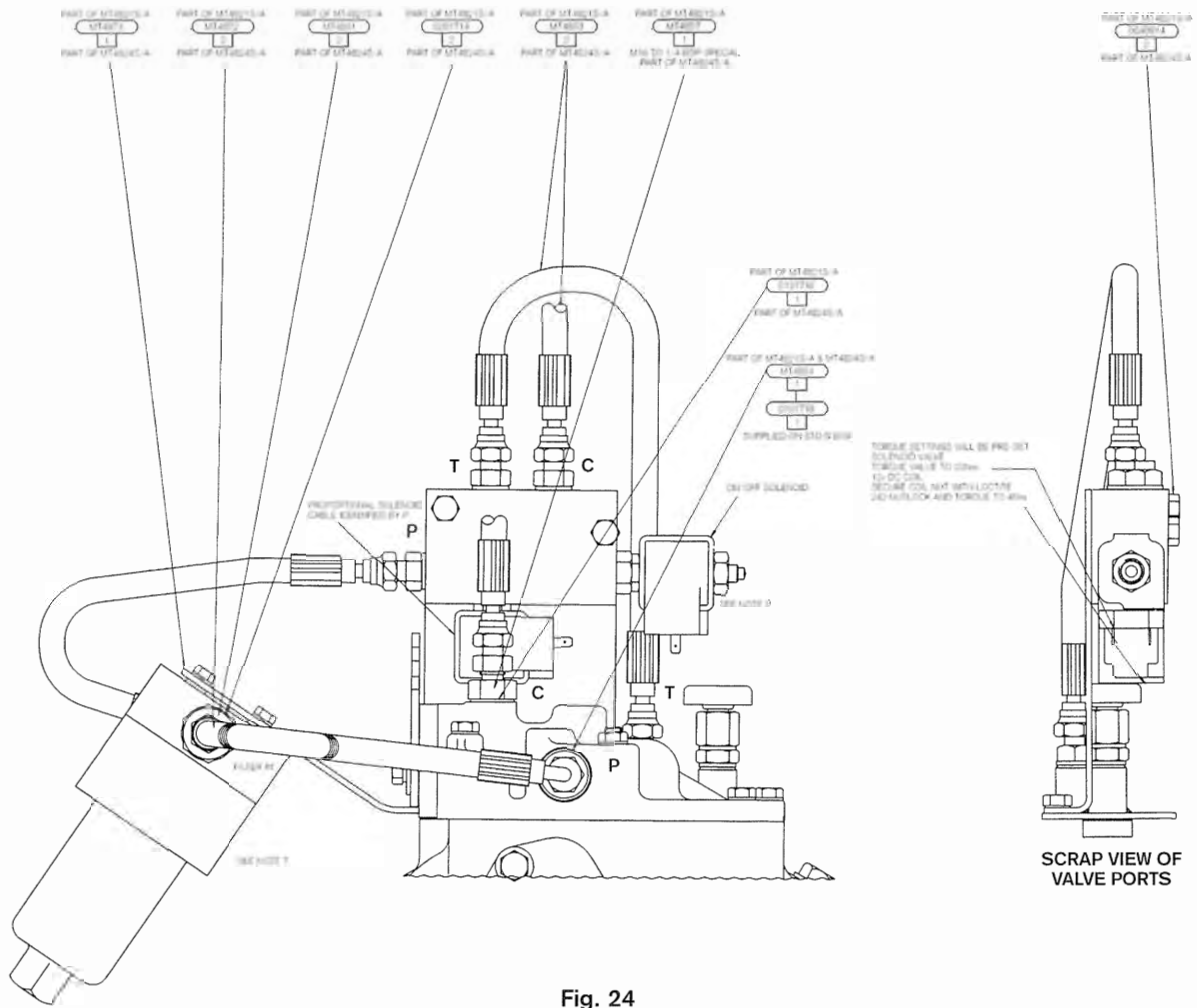
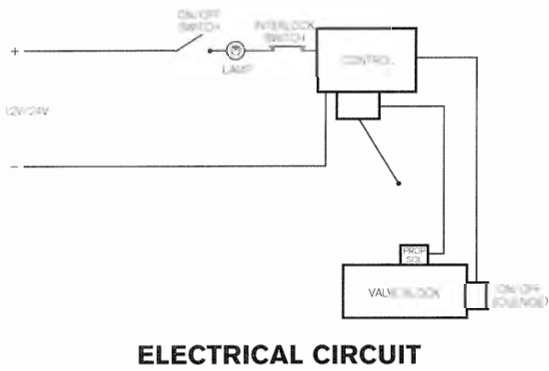
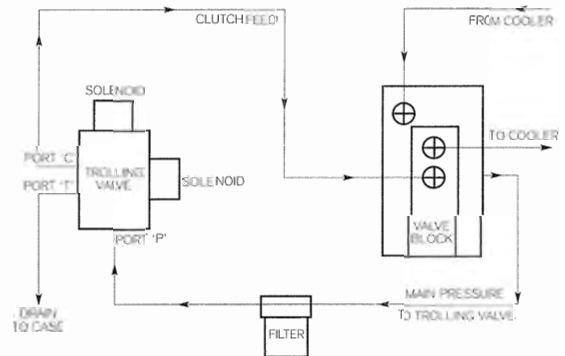

Fig. 24



ELECTRICAL CIRCUIT

Fig. 25



TROLLING VALVE BASIC CIRCUIT DIAGRAM

Fig. 26

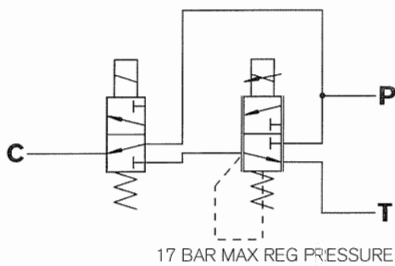

SCHEMATIC LAYOUT

Fig. 27

PART NUMBER	DESCRIPTION
MT4821S/A	TROLLING VALVE ASSEMBLY 260
MT4824S/A	TROLLING VALVE ASSEMBLY 500, 750, 1000
MT4885S/A12V	OPERATING LEVER ASSEMBLY
MT4886S/A24V	OPERATING LEVER ASSEMBLY

### 14.3 Trolling valve fitting instructions.

1. MT4820 one 3m length 6 core cable to be supplied loose with one socket end connector and two Hirschman connectors on solenoid cables. If required one 3m 6 core extension cable can be supplied part number MT4867.
2. Fuel rack switch to be left with bare wires. Customer to connect wires and supply mounting bracket.
3. When retrofitting trolling valve to a standard gearbox use MT1538 control valve within the valve block assembly.
4. Prior to retrofitting trolling valve to old gearbox, drain gearbox and cooler and clean drain plug. Refill with clean oil to the correct level. Run the gearbox to fill cooler circuit and re-fill accordingly.
5. The control lever is pre-set and should not require any adjustment.
6. Cooler pipe connections remain as standard gearbox.
7. The oil filter can be resited if necessary up to  $\frac{1}{2}$  metre from the gearbox. If this is desired the customer must supply the additional filter bracket. The filter must be installed vertically on the engine and gearbox installation with the bowl facing downwards. Replace 10 micron element after initial 50hrs operation and as determined by the filter indicator reading thereafter. The system must not be run with the filter indicator in the red.
8. If used with a clutch PTO, then the clutch pressure feed must be taken from the  $\frac{1}{8}$  BSP tapping in the valve block or port 'P' in the proportional valve. Under no circumstances should the PTO connection be taken from port 'C' clutch feed line. Any pipes left disconnected must be capped with plugs to prevent any contamination of the valve assembly.
9. The trolling valve system is failsafe and will return to full pressure in the event of electrical failure. In the event of mechanical failure eg. (sticking valve) the on/off solenoid on the side of the proportional valve can be manually moved by depressing the button in the centre of the solenoid. This will release the valve and return to full pressure.
10. The trolling valve system must not be operated above 1200 rpm engine speed. An interlock switch is provided to switch off the trolling valve should overspeed occur.



## 15. TOOL KIT

Dipstick	18mm A/F
Drain plug	1 in. A/F
Output flange nut	<sup>11</sup> / <sub>8</sub> in. A/F
Pump socket screws	<sup>5</sup> / <sub>16</sub> in. A/F Hex key
Spanners	19mm A/F
	17mm A/F
	13mm A/F

15.1 Tightening torques. **NOTE:** These figures are for dry threads only.

RECOMMENDED TIGHTENING TORQUES		
	Nm	lbf.ft
Upper to lower gearcase bolts	56.0	41.5
Upper to lower gearcase studs	56.0	41.5
Upper to lower gearcase nuts	56.0	41.5
Valve block to upper gearcase	28.0	21.0
Operating lever to selector valve	28.0	20.6
End cover to valve block (Loctite)	9.5	7.0
Top cover to upper gearcase	28.0	21.0
Pump body to gearcase	56.0	41.5
Pump cover to pump body	28.0	21.0
End cover to gearcase	98.0	72.5
Oil seal housing to gearcase	56.0	41.5
Output bearing retaining bolts	11.7	8.6
Output coupling to output shaft	340.0	250.0
Adaptor plate to gearbox : bolts/nuts	98.0	72.5
: studs	68.6	50.6
Adaptor plate to angle drive : bolts/nuts	98.0	72.5
: studs	68.6	50.6
Power take-off to rear gearcase	98.0	72.5
In-line case halves	98.0	72.5
In-line unit to main gearbox	98.0	72.5
Angle drive case halves	98.0	72.5
Angle drive to front gearcase	98.0	72.5

## 16. REPLACEMENT PARTS ORDERING

When ordering replacement parts the following should be quoted:

- Gearbox model and serial number
- Description(s) and part number(s) of the component(s) required
- Quantity required
- Orders and enquiries for replacement parts must be made through Newage distributor/dealer network

**NOTE:** Enquiries relating to a technical or service nature can be made direct to:

**NEWAGE TRANSMISSIONS LTD.  
BARLOW ROAD  
COVENTRY CV2 2LD  
ENGLAND**

**TEL: +44 (0)24 7661 7141  
FAX: +44 (0)24 7661 1845**

# PARTS LIST

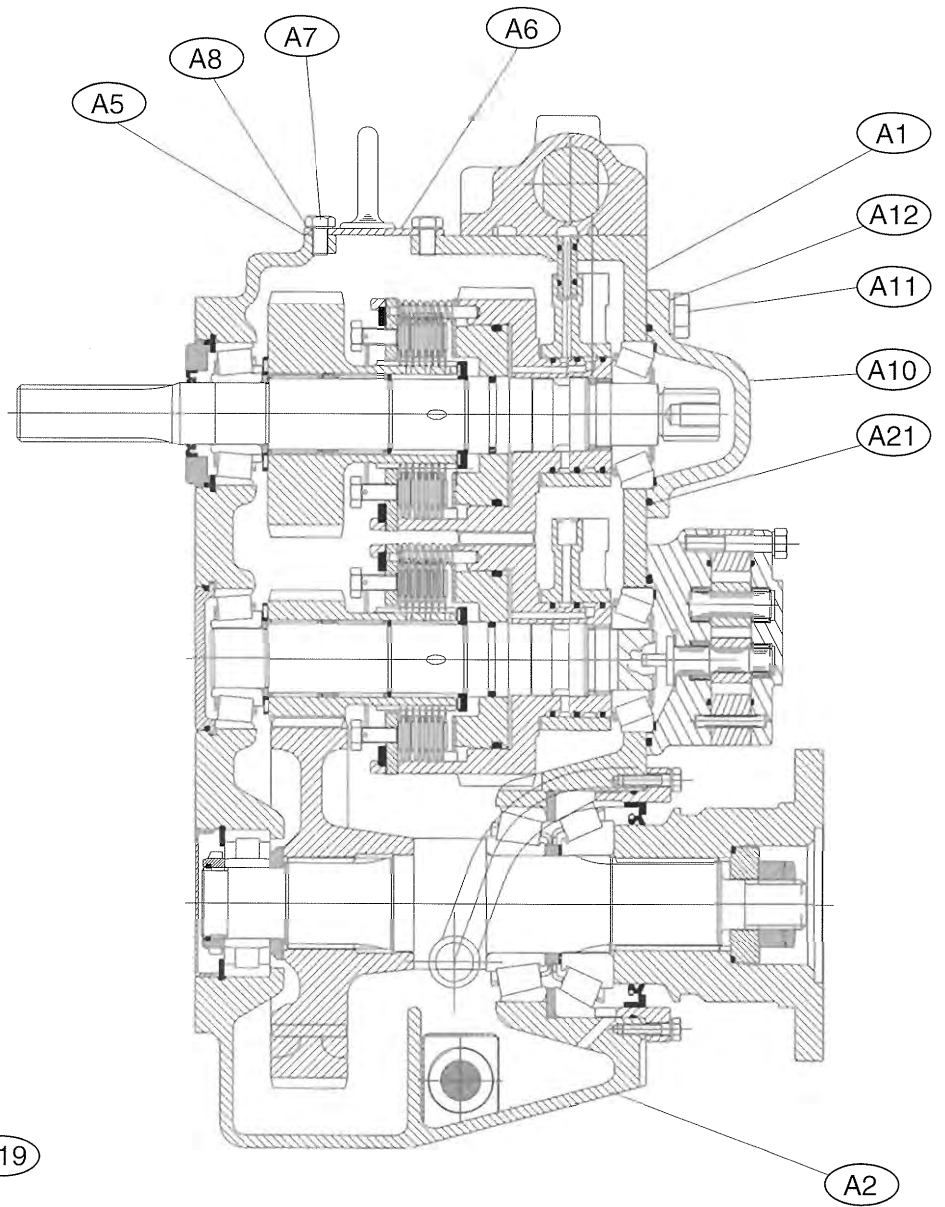
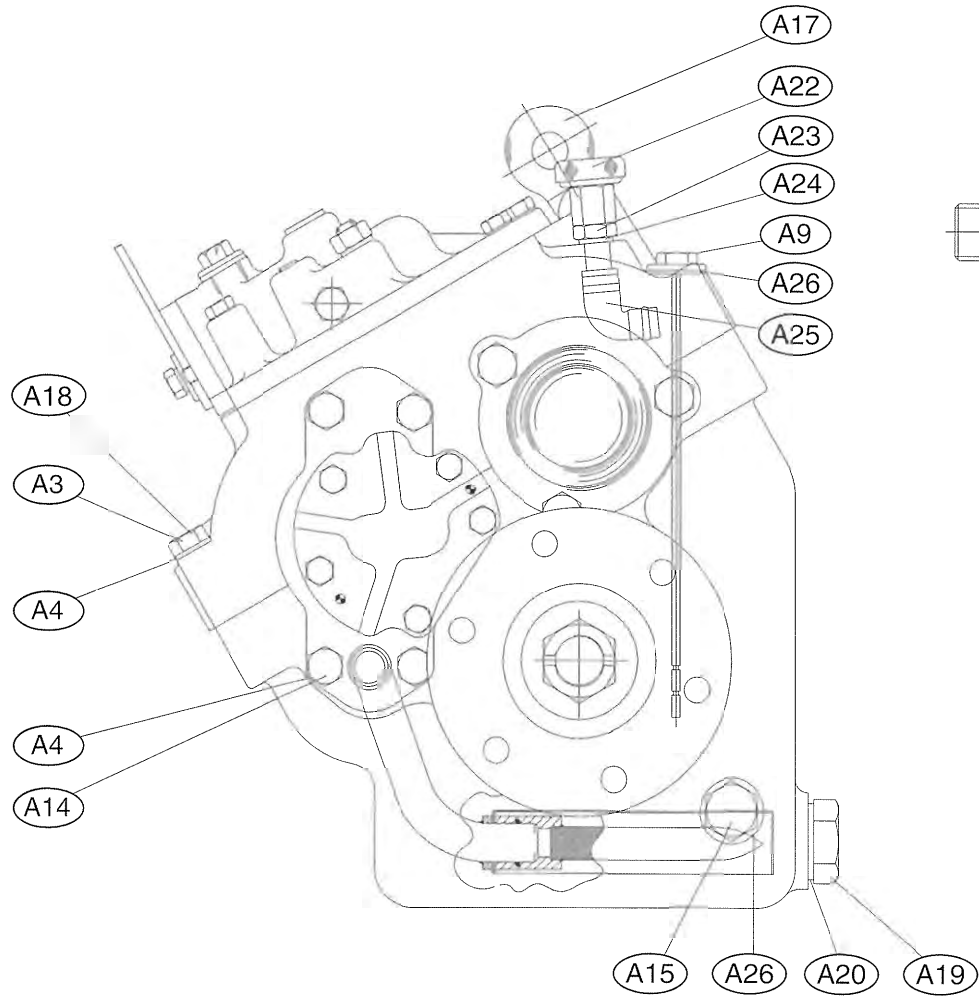

<b>SECTION A - GEARCASE ASSEMBLY</b>			
<b>ITEM NO.</b>	<b>DESCRIPTION</b>	<b>PART NO.</b>	<b>QTY</b>
A	Case sub-assembly	MT0316	1
A1 & A2	Gearcase sub assembly - supplied complete only	MT0402	1
A3	Bolt	0041014	6
A4	Washer	0191710	11
A5 *	Gasket (top cover)	MT343	1
A6	Top cover	MT1467	1
A7	Screw	0040804	1
A8	Washer	CP1223	1
A9	Dipstick	MT472	1
A10	End cover	MT1267	1
A11	Screw	0041208	3
A12	Washer (spring)	0191107A	3
A14	Bolt	0041010	4
A15	Drain plug - magnetic	CP1331	1
A16	Washer	CP1068	1
A17	Eyebolt	CP1339	1
A18	Bolt	0041019	1
A19	Drain plug	0150100	1
A20	Washer	0201720	1
A21 *	'O' ring	0430771	1
A22	Breather	CP1383	1
A23	Locknut	CP1385	1
A24	Washer	CP1204	1
A25	Breather tube assembly	CP1382S/A	1
A26	Bonded washer	0201714	1
4:1 ratio only:-			
A1 & A2	Case sub-assembly - supplied complete only	MT0312	1
A9	Dipstick	0800925	1

\* Part of gasket/seal kit MT0435

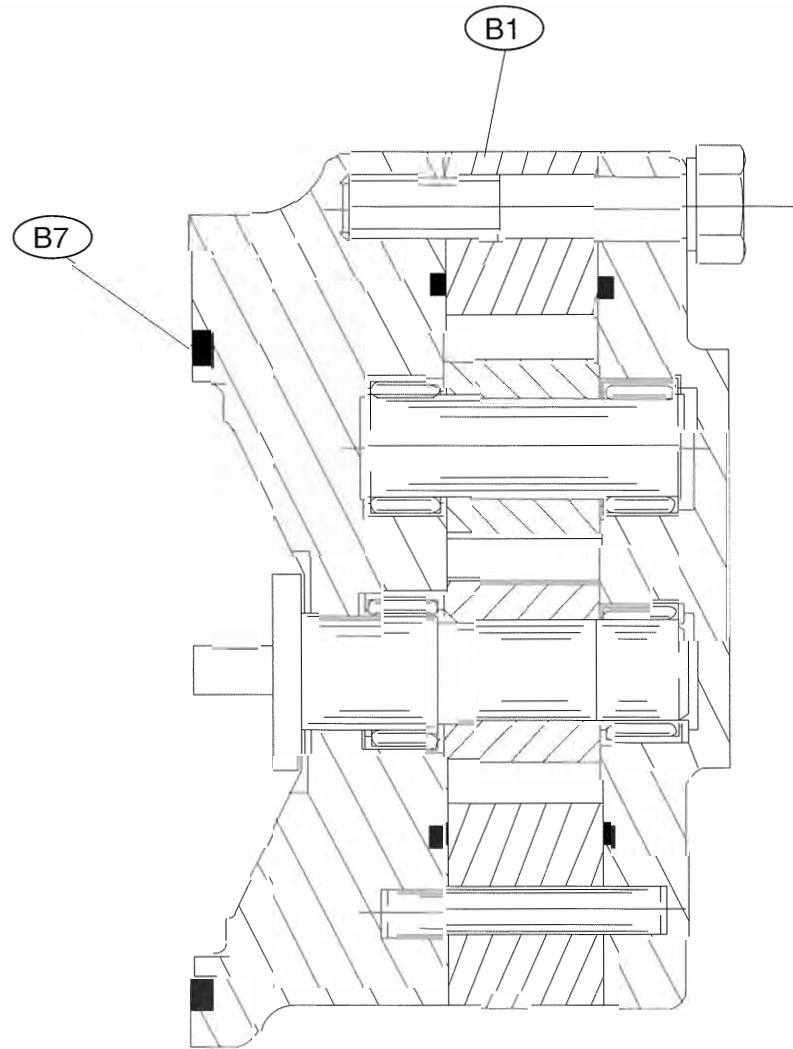
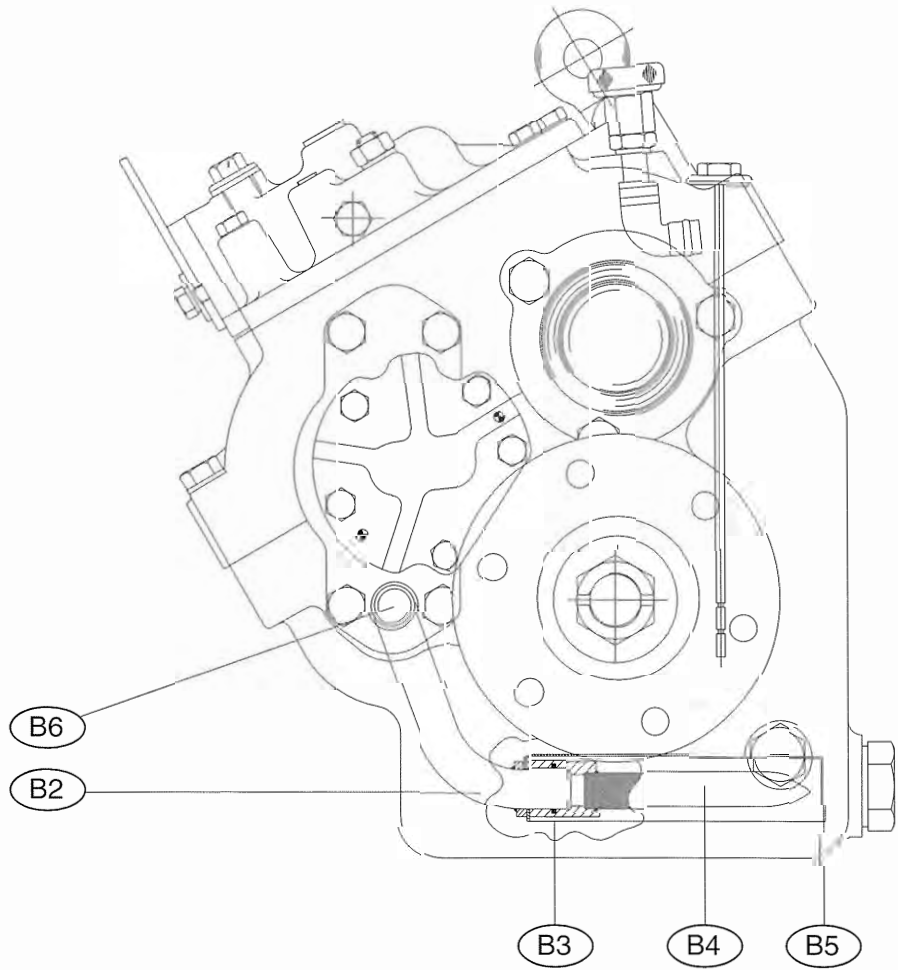

<b>SECTION B - OIL PUMP ASSEMBLY</b>			
<b>ITEM NO.</b>	<b>DESCRIPTION</b>	<b>PART NO.</b>	<b>QTY</b>
B1	Oil pump (Kit)	MT0412-KIT	1
B2	Oil pipe	MT4945S/A	1
B2	Oil pipe 4:1 ratio only	MT4997S/A	1
B3 *	'O' ring	000872	1
B4	Strainer	MT4547	1
B5	Baffle	MT1504	1
B6 *	'O' ring	001254	2
B7 *	'O' ring	003383	1

\* Part of gasket/seal kit      MT0435

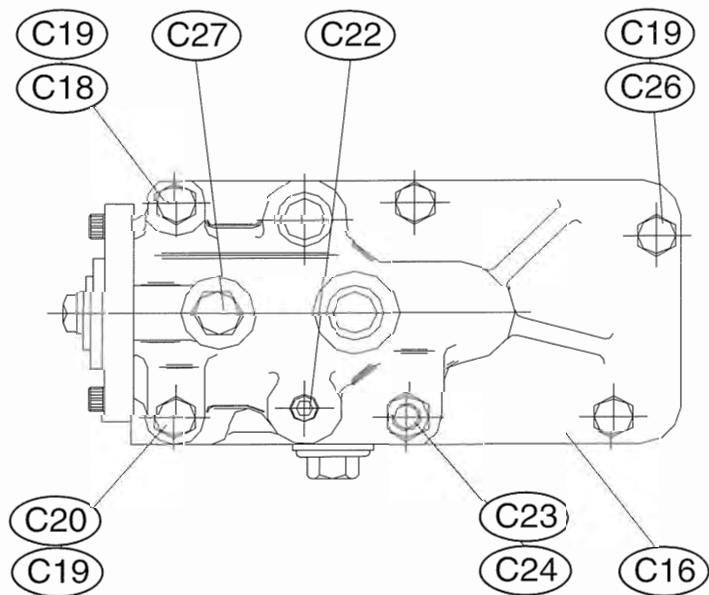
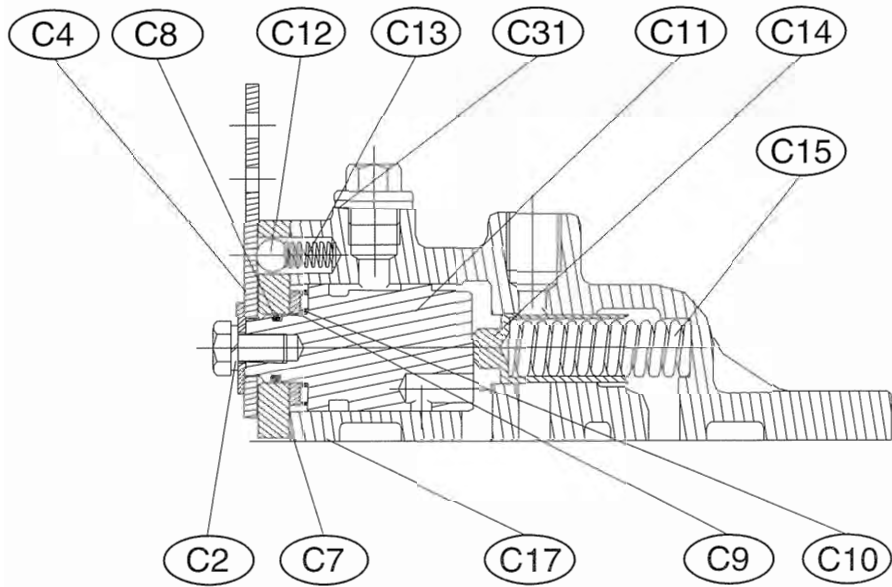
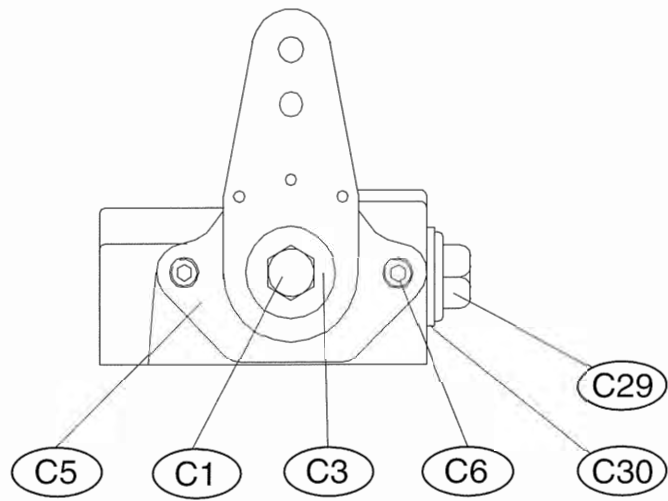

<b>SECTION C - VALVE BLOCK ASSEMBLY</b>			
<b>ITEM NO.</b>	<b>DESCRIPTION</b>	<b>PART NO.</b>	<b>QTY</b>
C	Valve block assembly	MT0411	1
C1	Screw	0040806	1
C2	Spring washer	0191105	1
C3	Washer	MT979	1
C4	Operating lever	MT977	1
C5	End cover	MT978	1
C6	Cap screw	0081220	2
C7 *	Gasket	MT1081	1
C8 *	Nu-lip seal	MT8082	1
C9	Thrust race	CP1308	1
C10	Thrust bearing	CP1307	1
C11	Control valve	MT4656	1
C12	Detent ball	CP1077	1
C13	Detent spring	MT305	1
C14	Piston	MT4751	1
C15	Valve spring 3000 Kpa (440 psi)	MT4928	1
C16	Valve block	MT4780	1
C17 *	Gasket	MT1073	1
C18	Bolt	0040812	1
C19	Washer	CP1223	5
C20	Bolt	0040815	1
C21	Redcap seal (transit only)	MT477	2
C22	Pressure plug	MT311	1
C23	Nut	0051001	1
C24	Washer	0191710	1
C25	Stud	MT1292	1
C26	Screw	0040808	3
C27	Washer	0201715	1
C28	Plug	CP1360	1
or			
C28	Switch and ball assy	MT0214	1
C29	Bonded seal	0191718	1
C30	Plug (M18 pressure port)	0150318	1

\* Part of valve block gasket kit MT0392 or gasket/seal kit MT0435



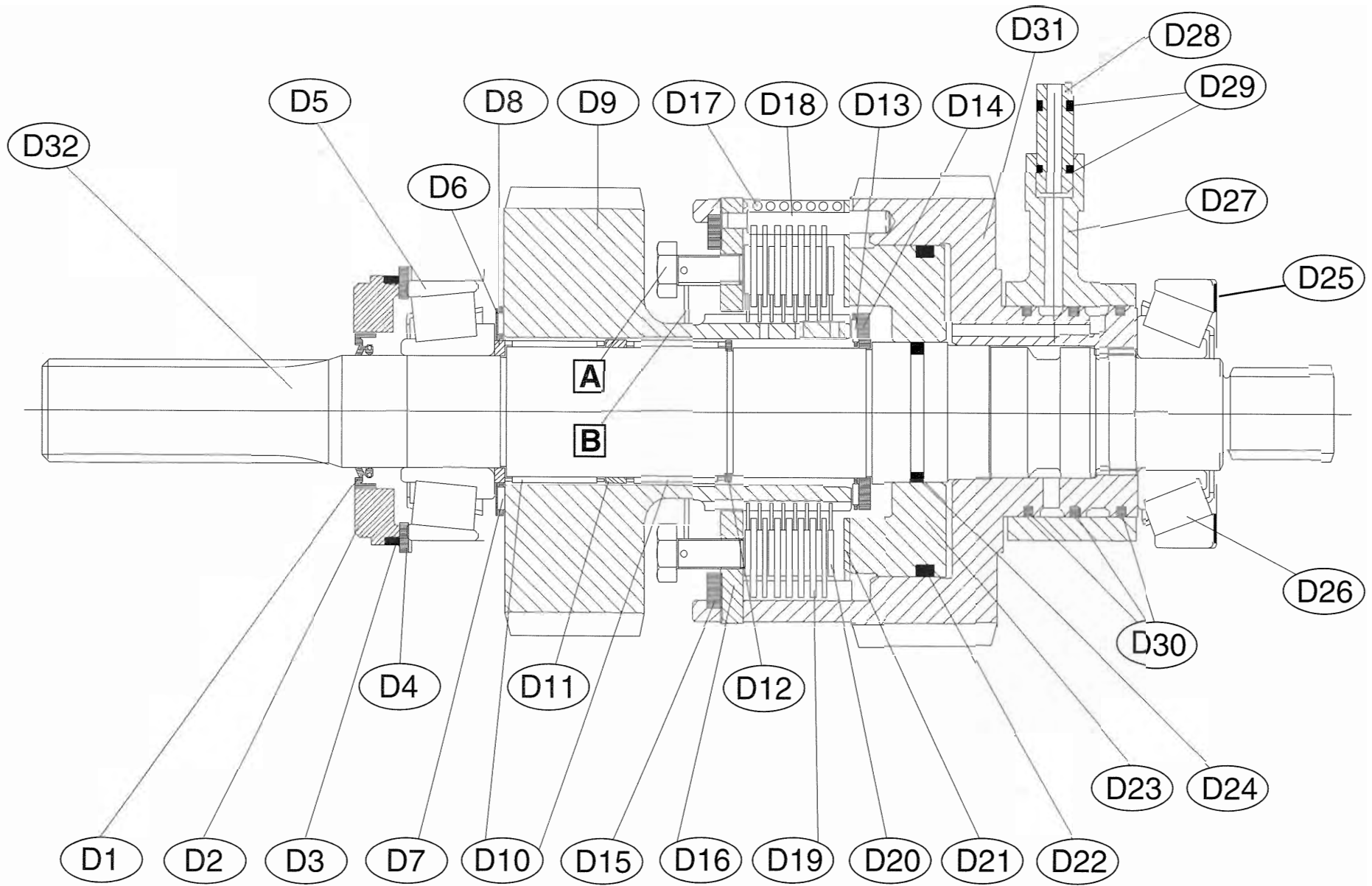

SECTION D - INPUT SHAFT ASSEMBLY			
ITEM NO.	DESCRIPTION	PART NO.	QTY
D1 *	Oil seal - not used on 750A/C	MT251	1
D2	Oil seal housing - not used on 750A/C	MT1514	1
D3 *	'O' ring	04306725	1
D4	Thrust washer	MT1516	1
D5	Bearing cup	055U044	1
	Bearing cone	055C019	1
D6	Thrust washer	0673801	1
D7	Thrust bearing	0603801	1
D8	Spacer	MT1471	1
D9	Pinion (1:1) 43T	MT1582	1
D9	Pinion (1.5:1) 37T	MT1583	1
D9	Pinion (2:1) 31T	MT1475	1
D9	Pinion (2.5:1) 23T	MT1476	1
D9	Pinion (3:1) 21T	MT1477	1
D9	Pinion (4:1) 21T	MT1477	1
D10	Needle roller bearing	0563501	2
D11	Spacer	MT1472	1
D12	Snap ring	0300350	1
D13	Thrust bearing	0603501	1
D14	Thrust washer	0673503	1
D15 •	Circlip	0251020	1
D16 •	Clutch end cover	MT1484S/A	1
D17 •	Spring	MT1067	3
D18 •	Clutch pin	MT1485	3
D19 •	Clutch plate - driven	MT982	7
D20 •	Clutch plate - driver	MT725/S	8
D21 •	End plate	MT983	1
D22 *	Piston 'O' ring	003504	1
D23	Piston	MT1264	1
D24 *	Piston 'O' ring	0421503	1
D25 **	Shim 0.002"	MT1077/02	AR
	Shim 0.010"	MT1077/10	AR
	Shim 0.031"	MT1077/31	AR
D26	Bearing	0540302	1
D27	Feeder	MT380	1
D28	Feeder connector	MT1057	2
D29 *	Feeder 'O' ring	000372	4
D30 !	Piston ring	MT292	3
D31	Clutch gear RH (identification groove in teeth)	MT4853	1
D32	Input shaft	MT4935	1
	Input shaft (in-line only)	MT4944	1

• Part of clutch pack kit MT0349

\* Part of gasket/seal kit MT0435

! Part of piston ring kit MT0439

\*\* Part of shim kit MT0068

**NOTE:** AR as required.

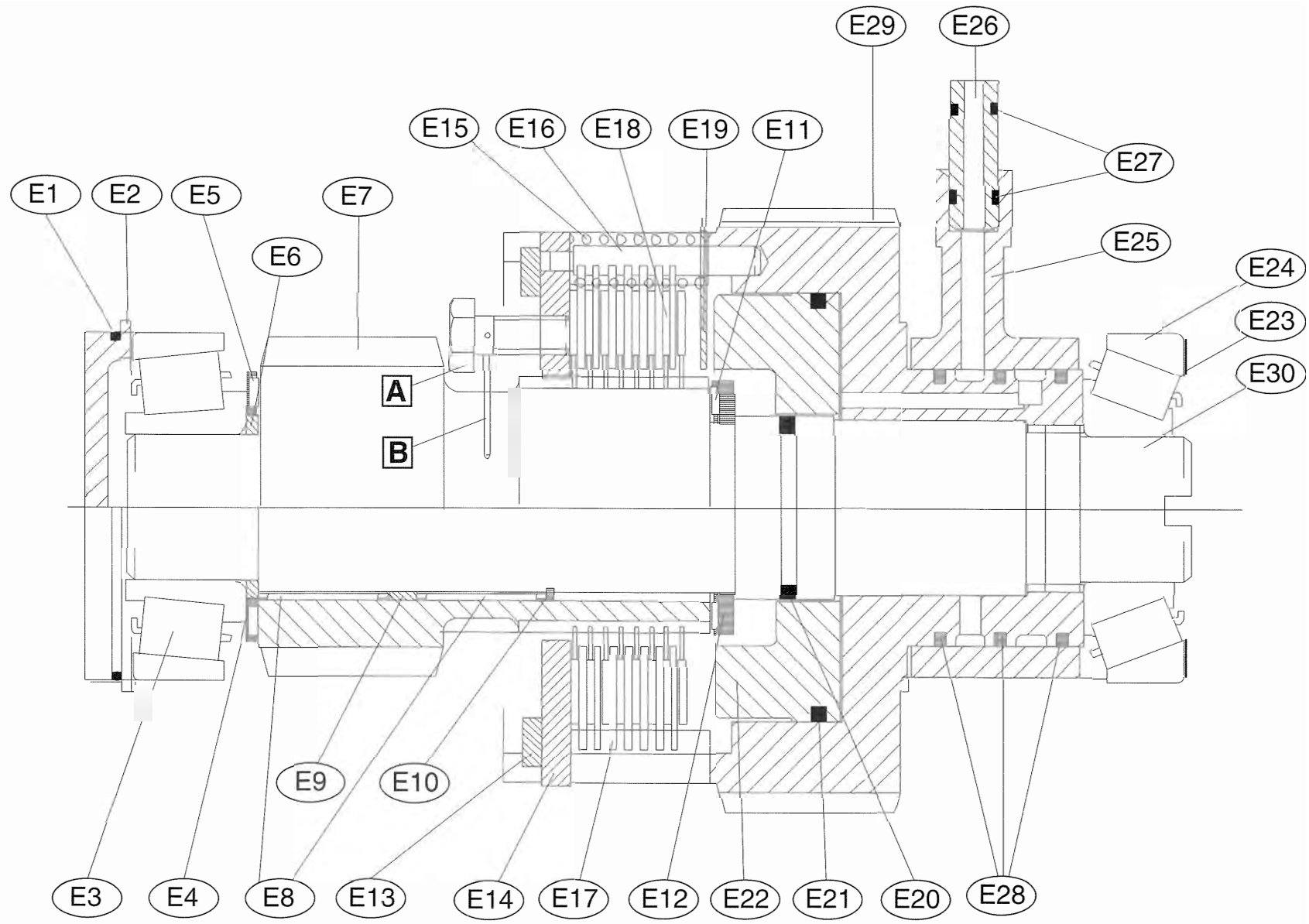

SECTION E - LAYSHAFT ASSEMBLY			
ITEM NO.	DESCRIPTION	PART NO.	QTY
E1 *	'O' ring	04306725	1
E2	End cover	MT1515	1
E3	Bearing cup	055U044	1
	Bearing cone	055C019	1
E4	Thrust washer	0673801	1
E5	Thrust bearing	0603801	1
E6	Spacer	MT1471	1
E7	Drive pinion (1:1) 43T	MT1582	1
E7	Drive pinion (1.5:1) 37T	MT1583	1
E7	Drive pinion (2:1) 31T	MT1475	1
E7	Drive pinion (2.5:1) 23T	MT1476	1
E7	Drive pinion (3:1) 21T	MT1477	1
E7	Drive pinion (4:1) 21T	MT1477	1
E8	Needle roller bearing	0563501	2
E9	Spacer	MT1472	1
E10	Snap ring	0300350	1
E11	Thrust bearing	0603501	1
E12	Thrust washer	0673503	1
E13 •	Circlip	0251020	1
E14 •	Clutch end cover	MT1484S/A	1
E15 •	Spring	MT1067	3
E16 •	Clutch pin	MT1485	3
E17 •	Clutch plate - driven	MT982	7
E18 •	Clutch plate - driver	MT725/S	8
E19 •	End plate	MT983	1
E20 *	Piston 'O' ring	0421503	1
E21 *	Piston 'O' ring	003504	1
E22	Piston	MT1264	1
E23 **	Shim 0.002"	MT1077/02	AR
E23 **	Shim 0.010"	MT1077/10	AR
E23 **	Shim 0.031"	MT1077/31	AR
E24	Bearing	0540302	1
E25	Feeder	MT380	7
E26	Feeder connector	MT1057	2
E27 *	Feeder 'O' ring	000372	4
E28 !	Piston ring	MT292	3
E29	Clutch gear LH	MT4854	1
E30	Layshaft	MT1500	1

• Part of clutch pack kit MT0349

! Part of piston ring kit MT0439

\* Part of gasket/seal kit MT0435

\*\* Part of shim kit MT0068

**NOTE:** AR as required.

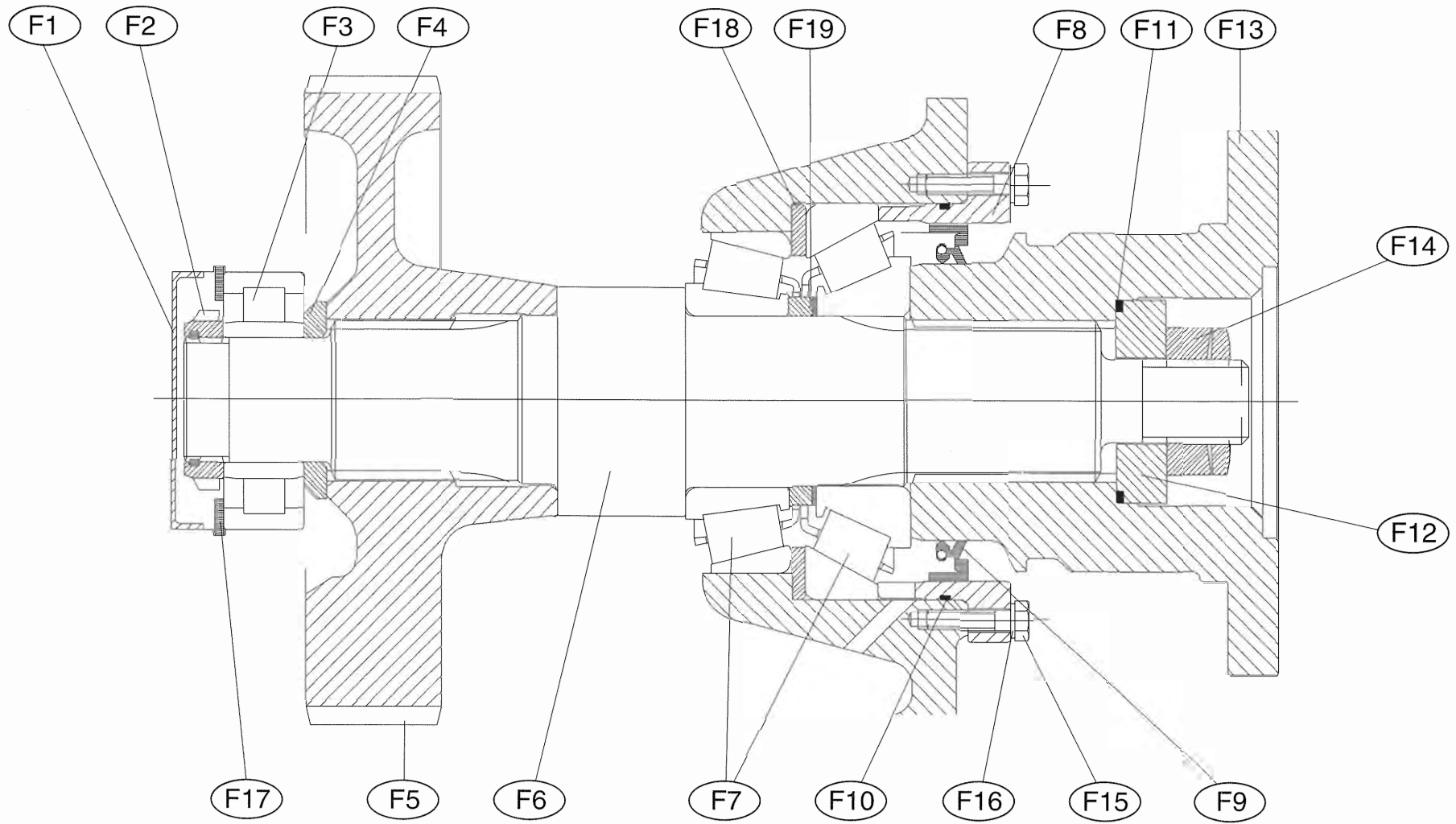

SECTION F - OUTPUT SHAFT ASSEMBLY			
ITEM NO.	DESCRIPTION	PART NO.	QTY
F1 *	Shamban seal - not used with 750A/C	06907209	1
F2	Locknut	CP1406	1
F3	Bearing	0533532	1
F4	Spacer	MT4925	1
F5	Output gear 1:1 47T	MT4917	1
	Output gear 1.5:1 54T	MT4918	1
	Output gear 2:1 60T	MT4919	1
	Output gear 2.5:1 59T	MT4920	1
	Output gear 3:1 61T	MT4828	1
	Output gear 4:1 83T	MT4927	1
F6	Output shaft	MT4827	1
F7	Bearing assembly (incl. F18/F19)	MT0455	1
F8	Seal housing (incl. seal F9)	MT4943S/A	1
F9 *	Output seal	0400781	1
F10 *	'O' ring	0431071	1
F11 *	'O' ring	04305025	1
F12	Coupling washer	MT4947	1
F13	Output coupling	MT4829	1
F14	Locknut	0472410ZP	1
F15	Screw	0040608HTZP	8
F16	Spring washer	0191104ZP	8
F17	Circlip	CM2077	1
F18	Spacer	} Part of } Assembly F7	1
F19	Shim washer		1

\* Part of gasket/seal kit MT0435

**NOTE:** Item F7 bearing assembly is only sold complete. It is a factory adjusted item and cannot be purchased as individual parts.

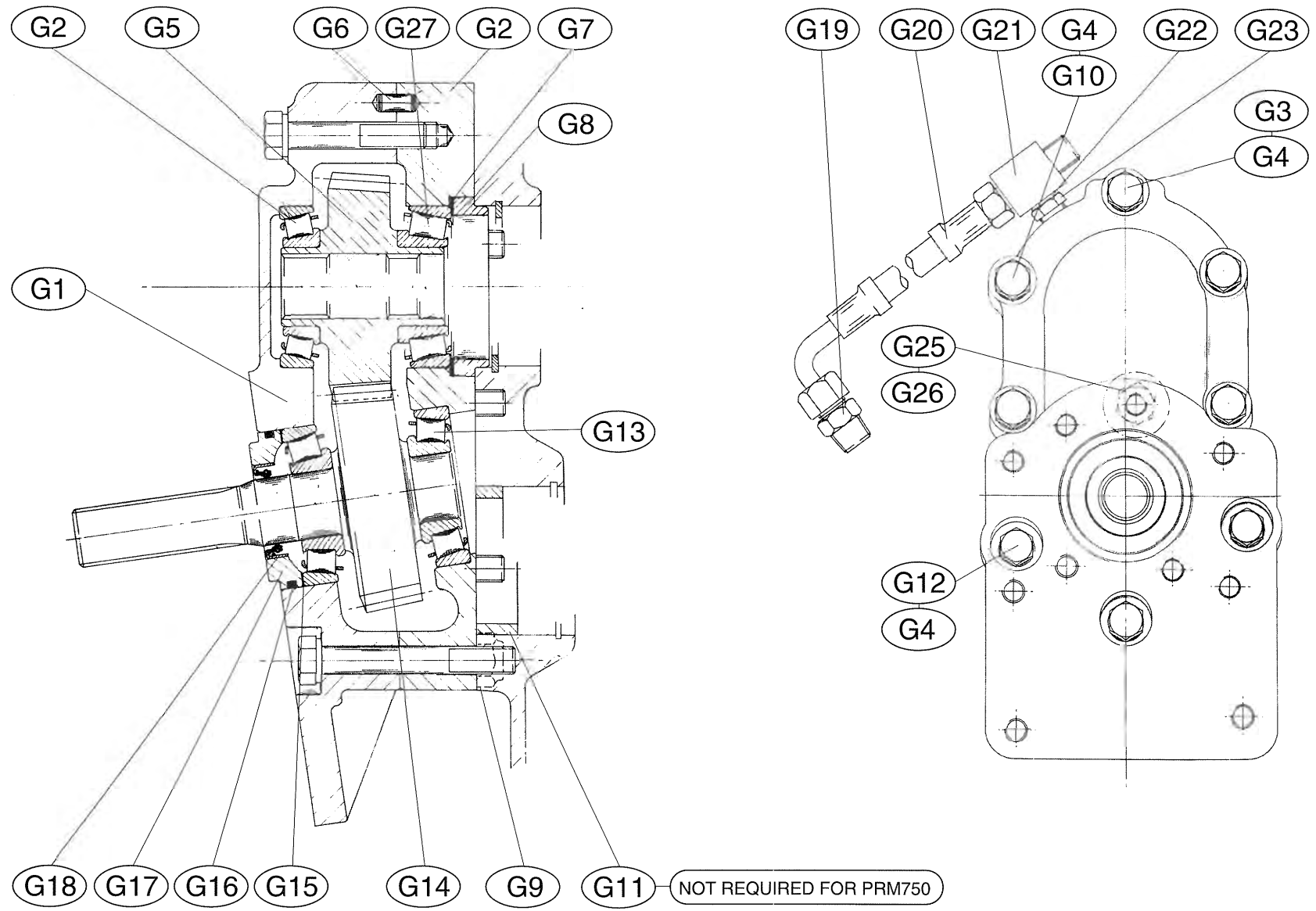

SECTION G - DOWN ANGLE DRIVE UNIT			
ITEM NO.	DESCRIPTION	PART NO.	QTY
G	Down angle drive unit	MT0210	1
G1	Gearcase S/A	MT0189	1
	Half case (front) - not supplied separately	MT1273	1
	Half case (rear) - not supplied separately	MT1274	1
G2	Taper roller bearing	0540351	1
G3	Bolt	0041216	1
G4	Dowty seal washer	CP1204	8
G5	Output Gear	MT1527	1
G6	Dowel	0210815	2
G7	Shim 0.002"	057313A	AR
	Shim 0.10"	057313C	AR
	Shim 0.031"	057313E	AR
G8	Location ring	MT1512	1
G9	Gasket	MT1281	1
G10	Bolt	0041222	4
G11	Spacer (Not required for PRM750)	MT1271	1
G12	Bolt	0041221	3
G13	Taper roller bearing	0540302	2
G14	Input gear	MT1525	1
G15 **	Shim 0.002"	MT1077/02	AR
G15 **	Shim 0.010"	MT1077/10	AR
G15 **	Shim 0.031"	MT1077/31	AR
G16 *	'O' ring	002874	1
G17	End cover	MT1068	1
G18 *	Oil seal	MT251	1
G19	Adaptor	CP1255	1
G20	Oil pipe	MT766	1
G21	Tee piece	CP1367	1
G22	Washer	0201715	1
G23	Metering union	MT4583	1
G25	Washer - transit only	CM2123	
G26	Screw - transit only	0041206	
G27	Taper bearing	0540353	1

\* Part of gasket/seal kit MT0435

\*\* Part of Shim Kit MT0068

**NOTE:** AR as required.



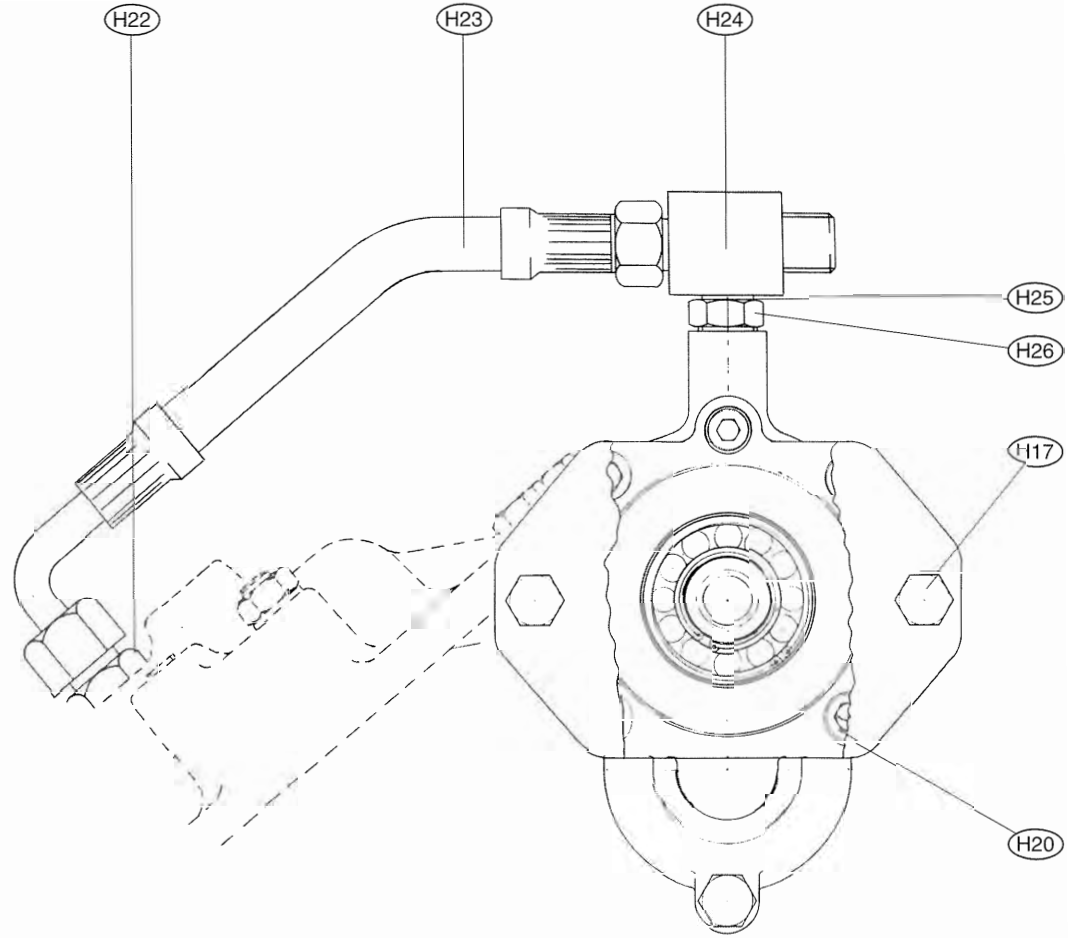
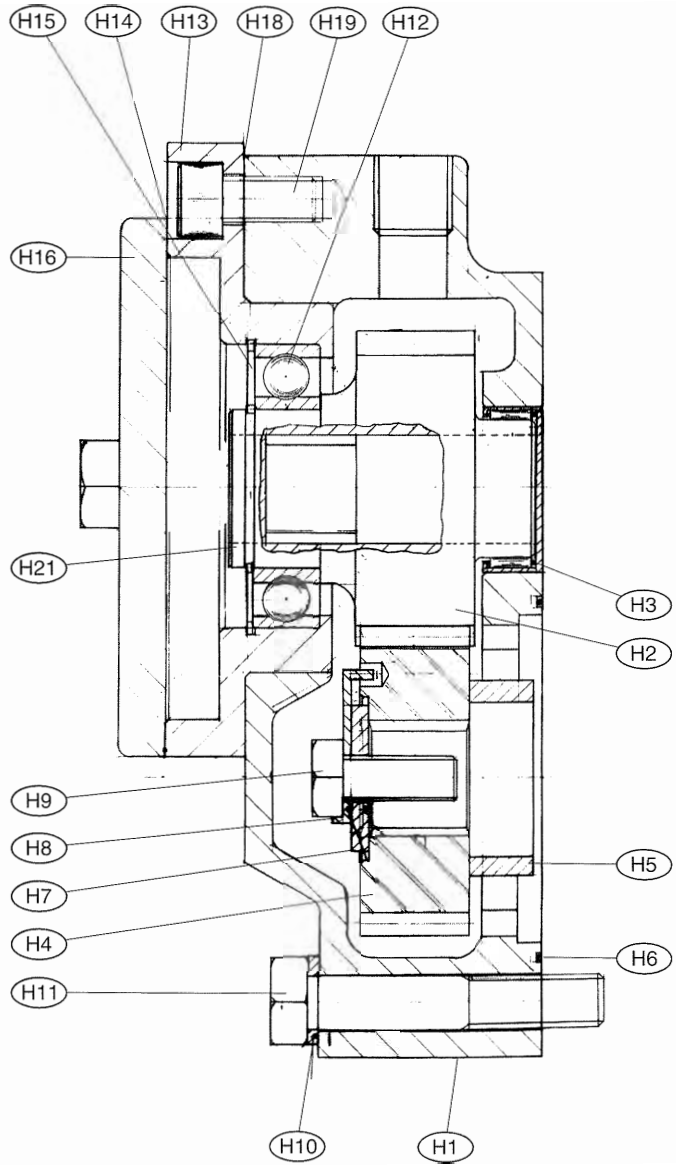

<b>SECTION H - POWER TAKE-OFF</b>			
<b>ITEM NO.</b>	<b>DESCRIPTION</b>	<b>PART NO.</b>	<b>QTY</b>
H	Power Take-Off	MT0193	1
H1	PTO housing	MT1300	1
H2	Driven gear	MT1297	1
H3	Needle bearing	0563003	1
H4	Driving gear	MT1296	1
H5	Spacer	MT1589	1
H6 *	'O' ring	0430771	1
H7	Washer	MT1301	1
H8	Tab washer	MT1302	1
H9	Screw	0041008	1
H10	Spring washer	0191107	3
H11	Bolt	0041216	1
H12	Ball bearing	40M433	1
H13	Adaptor flange	MT1299	1
H14	Gasket 4 bolt	MT1307	1
H14	Gasket 2 bolt	MT5012	1
H15	Circlip	0250620	1
H16	Cover plate - transit only	MT1293	1
H17	Screw	0041208	2
H18	Gasket	MT1303	1
H19	Cap screw	0081520	1
H20	Cap screw	0081685	2
H21	Circlip	CM2067	1
H22	Adaptor	CP1255	1
H23	Oil pipe	MT766	1
H24	Tee piece	CP1367	1
H25	Washer	0201715	1
H26	Metering union	MT4583	1

\* Also part of gasket/seal kit MT0435

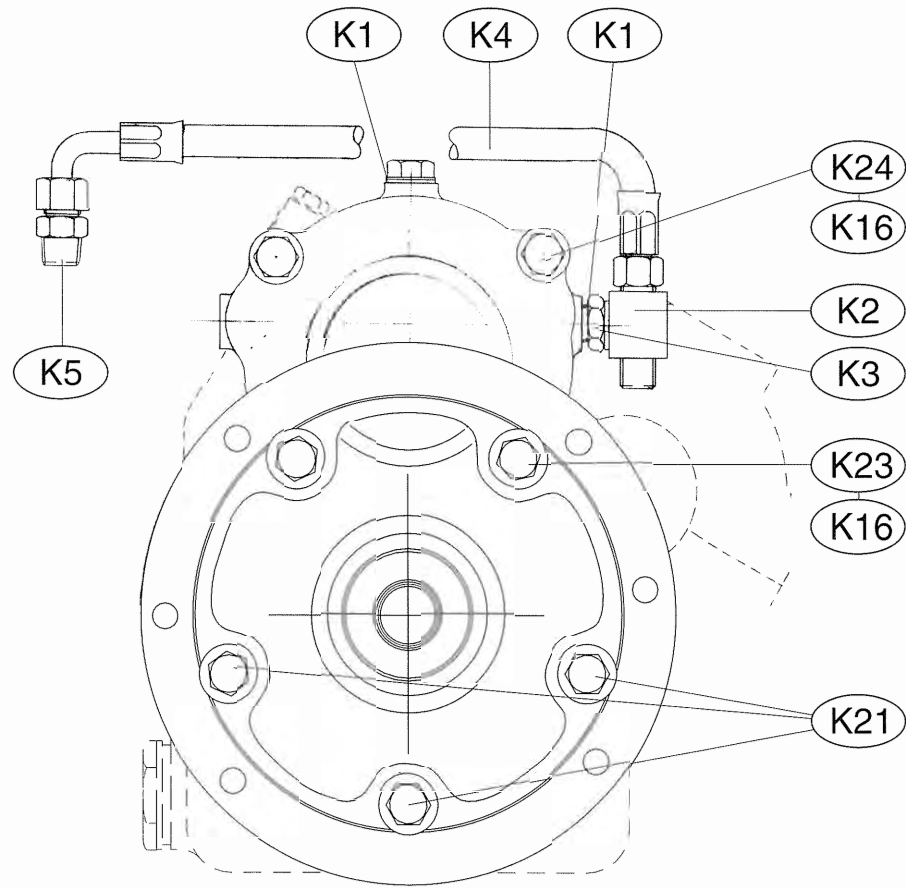
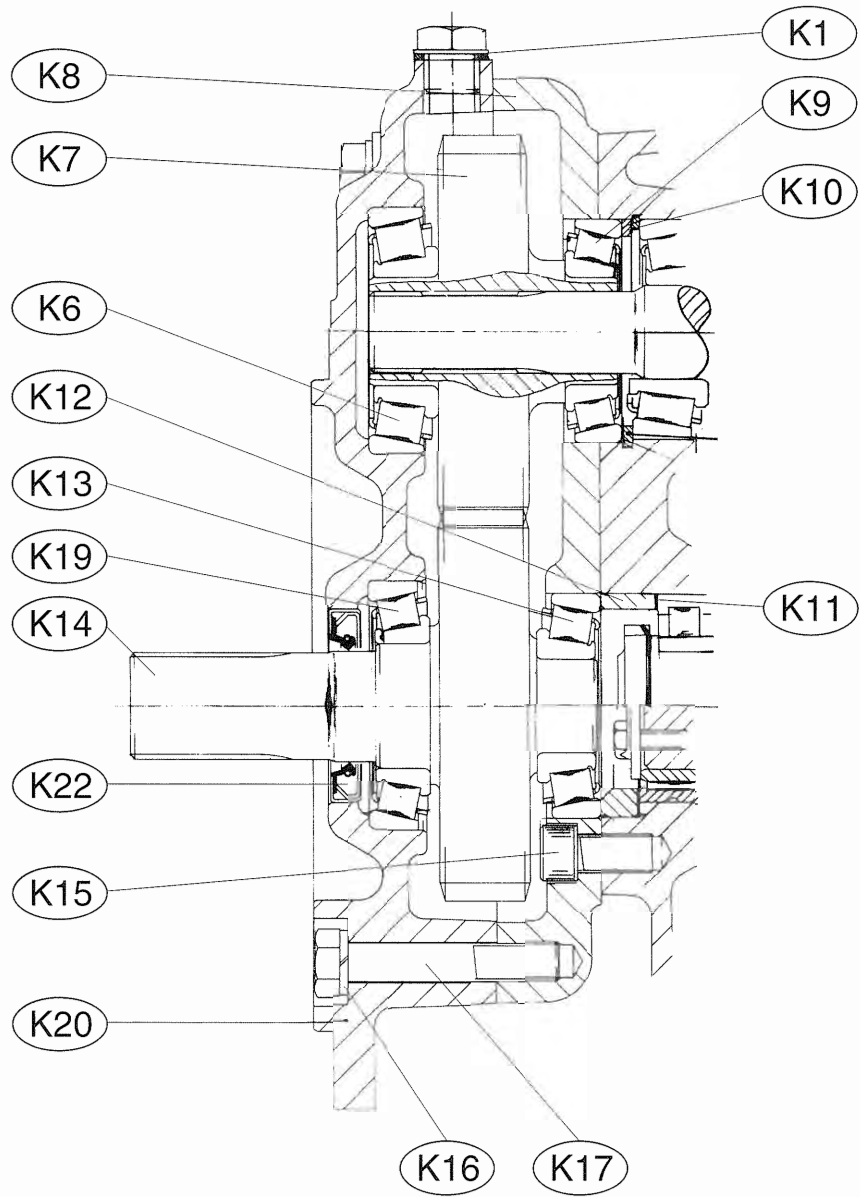

<b>SECTION K - IN-LINE UNIT</b>			
<b>ITEM NO.</b>	<b>DESCRIPTION</b>	<b>PART NO.</b>	<b>QTY</b>
K	In-line unit	MT0279	1
K1	Dowty washer	0201715	2
K2	Tee piece	CP1367	1
K3	Metering union	MT4583	1
K4	Oil pipe	MT767	1
K5	Adaptor	CP1255	1
K6	Bearing	0540354	1
K7	Gear 45T LH	MT1435	1
K8	Gearcase	MT1433	1
K9	Bearing	0540351	1
K10	Spacer	MT1465	1
K11 **	Shim 0.002"	MT1077/02	AR
K11 **	Shim 0.010"	MT1077/10	AR
K11 **	Shim 0.031"	MT1077/31	AR
K12	Spacer	MT1400	1
K13	Bearing	0540301	1
K14	Gear and shaft - 45T RH	MT1434	1
K15	Socket head screw	0081620	1
K16	Spring washer	0191107	11
K17	Bolt	0041208	4
K18	Dowel - not illustrated	0210614	2
K19	Bearing	0540402	1
K20	Gearcase	MT1432	1
K21	Bolt	0041217	3
K22	Oil seal	0400351	1
K23	Bolt	0041222	2
K24	Bolt	0041215	2
	<b>NOTE: Input shaft of main gearbox becomes</b>	<b>MT4944</b>	<b>1</b>

\*\* Part of shim kit MT0068

**NOTE: AR as required.**

## NOTES



*FROM*

**NEWAGE  
TRANSMISSIONS LIMITED**

Barlow Road, Coventry CV2 2LD England

Telephone: +44 (0)24 7661 7141

Fax: +44 (0)24 7661 1845

Email: [mail@newage-prm.co.uk](mailto:mail@newage-prm.co.uk)

Website: <http://www.newage-prm.co.uk>



© Newage Transmissions Limited.  
Newage Transmissions Ltd. is a member of BI Group Plc  
Registered in England - No 345283  
Registered Office - Neville House, 42-48 Hagley Road,  
Birmingham B16 8PZ  
Printed in England by Beechwood Litho (024) 7671 3792